

JMx

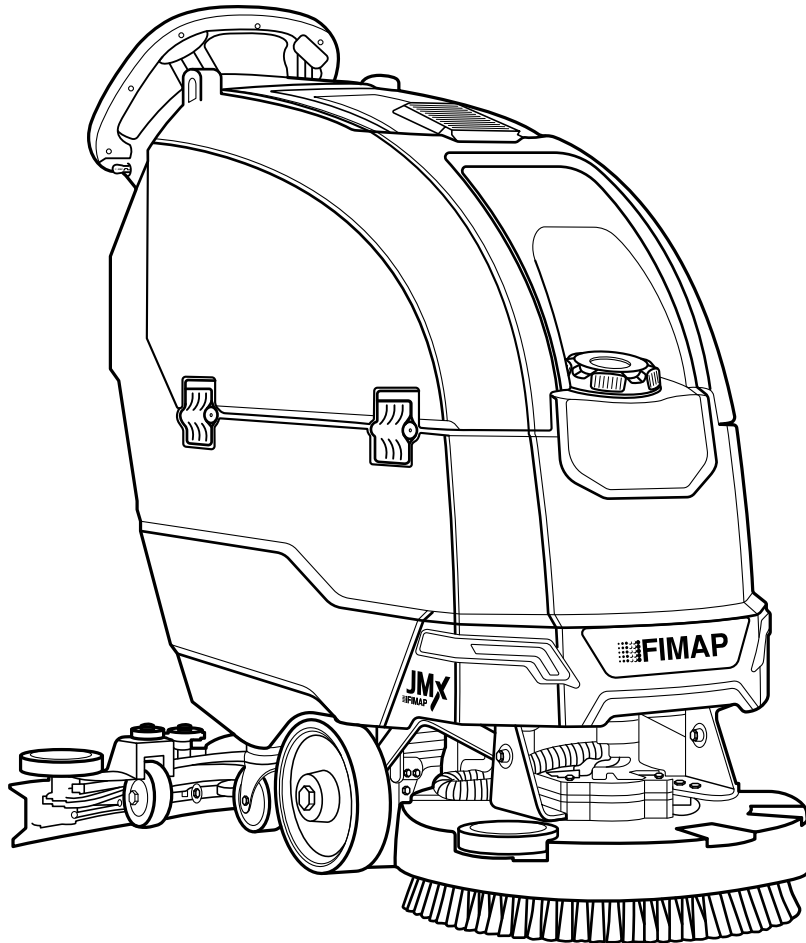

PROFESSIONAL SCRUBBING MACHINES

USE AND MAINTENANCE MANUAL

 **FIMAP**[®]



ORIGINAL INSTRUCTIONS

Document number: 910001259 Version: 01 Issue: 2025-01

CONTENTS

CONTENTS	3
DEFINITION OF LEVELS OF WARNING	5
GENERAL SAFETY REGULATIONS	5
GENERAL DESCRIPTION	5
REGULATIONS	5
SYMBOLS USED IN THE MANUAL.....	6
TECHNICAL DESCRIPTION.....	6
INTENDED USE.....	7
SAFETY.....	7
SERIAL NUMBER PLATE	8
MAIN MACHINE COMPONENTS	9
TECHNICAL DATA	10
SYMBOLS USED ON THE MACHINE	12
LABELS USED ON THE MACHINE	14
CONTROL STATION	17
DASHBOARD.....	17
CONTROL DISPLAY	18
CONTROL DISPLAY	19
PREPARATION OF MACHINE	19
HANDLING THE PACKAGED MACHINE	19
HOW TO UNPACK THE MACHINE	20
MACHINE SAFETY	22
HOW TO MOVE THE MACHINE.....	24
TYPE OF BATTERY TO BE USED	25
BATTERY MAINTENANCE AND DISPOSAL.....	25
INSERTING THE BATTERIES IN THE MACHINE.....	25
RECHARGING THE BATTERIES	27
INSERTING WATER SYSTEM FILTER	29
FILLING THE SOLUTION TANK.....	30
ASSEMBLY OF BRUSHES OR DRIVE DISCS.....	31
ASSEMBLING THE ABRASIVE PAD	32
ASSEMBLING THE SQUEEGEE BODY.....	32
ASSEMBLING THE SPLASH GUARD BRUSH HEAD	33
WORK PREPARATION CHECKLIST	34
WORKING PROGRAMS	35
ECO MODE WORKING PROGRAM.....	35
MANUAL MODE WORKING PROGRAM.....	36
WORKING MODE	36
TRANSFER WORKING MODE.....	36
SCRUBBER WORKING MODE	37
PRE-SCRUB WORKING MODE	38
DRYING WORKING MODE	39
STARTING WORK	40
ADDITIONAL FUNCTIONS	42
HOUR METER	42
BATTERY LEVEL INDICATOR.....	43
ADJUSTMENT OF THE DETERGENT SOLUTION FLOW	43
NOISELESS SUCTION.....	44
EXTRA PRESSURE FUNCTION (PRO VERSIONS).....	44
BRUSH UNCOUPLING FUNCTION	45
REVERSE GEAR	45
ALARM SCREEN	46
OPTIONAL FUNCTIONS	46
FRONT HEADLIGHTS	46
AT THE END OF THE WORK	46
MAINTENANCE PLAN	47

ROUTINE MAINTENANCE INTERVAL TABLE (NORMAL WORKER)	50
DAILY MAINTENANCE	50
MAINTENANCE AFTER 50 WORKING HOURS	50
ROUTINE MAINTENANCE INTERVAL TABLE (SPECIALIST WORKER).....	51
MAINTENANCE AFTER 50 WORKING HOURS	51
MAINTENANCE AFTER 100 WORKING HOURS	51
ROUTINE MAINTENANCE.....	52
CLEANING THE SQUEEGEE.....	52
CLEANING THE SQUEEGEE VACUUM HOSE	53
DRAINING THE RECOVERY TANK	54
RECOVERY TANK CLEANING	55
CLEANING OF THE SUCTION MOTOR AIR INTAKE FILTER.....	55
CLEANING THE BRUSH - PAD HOLDER	56
CLEANING THE BRUSH HEAD SPLASH GUARD	57
EMPTYING THE SOLUTION TANK.....	57
CLEANING THE SOLUTION TANK FILTER-CAP.....	58
EXTRAORDINARY MAINTENANCE WORK	59
REPLACING THE SQUEEGEE RUBBER BLADES	59
REPLACING THE BRUSHES OR PAD HOLDERS	61
REPLACING THE HEPA FILTER ON THE SUCTION MOTOR AIR OUTLET	62
ADJUSTMENT INTERVENTIONS.....	63
ADJUSTING THE SQUEEGEE RUBBER BLADES.....	63
DISPOSAL	65
CHOOSING AND USING BRUSHES	65
BRUSHES OR PAD HOLDERS	67
TROUBLESHOOTING	69
THE MACHINE DOES NOT START.....	69
AN ERROR APPEARS ON THE CONTROL DISPLAY	71
THE BATTERIES ARE NOT FULLY CHARGED	72
THE BATTERIES DO NOT WORK CORRECTLY.....	74
VERY LOW WORKING AUTONOMY.....	76
THE MACHINE DOES NOT MOVE	77
THE MACHINE DOES NOT CLEAN CORRECTLY	78
INSUFFICIENT DETERGENT SOLUTION ON THE BRUSHES	80
THE VACUUM SYSTEM DOES NOT WORK PROPERLY	82
EXCESSIVE FOAM PRODUCTION.....	85
EC DECLARATION OF CONFORMITY	86
UKCA DECLARATION OF CONFORMITY	88

DEFINITION OF LEVELS OF WARNING

 **DANGER:** indicates an imminent dangerous situation that, unless avoided, will result in death or serious injuries.

 **WARNING:** Indicates a potentially dangerous situation that, unless avoided, could cause death or serious injury.

 **ATTENTION:** Indicates a potentially dangerous situation that, unless avoided, could cause slight or moderate injuries.

 **N.B.:** instructs the reader to pay particular attention to the topic that follows.

GENERAL SAFETY REGULATIONS

Before using the machine, please read the following document carefully and follow the instructions contained herein, along with the instructions in the document supplied with the machine itself, "GENERAL SAFETY REGULATIONS" (document number 10083659).

GENERAL DESCRIPTION

The descriptions contained in this document are not binding. The company therefore reserves the right to make any modifications at any time to elements, details, or accessory supply, as considered necessary for reasons of improvement or manufacturing/commercial requirements. The reproduction, even partial, of the text and drawings contained in this document is prohibited by law.

The company reserves the right to make any technical and/or supply modifications. The images are for reference purposes only, and are not binding in terms of design and supply.





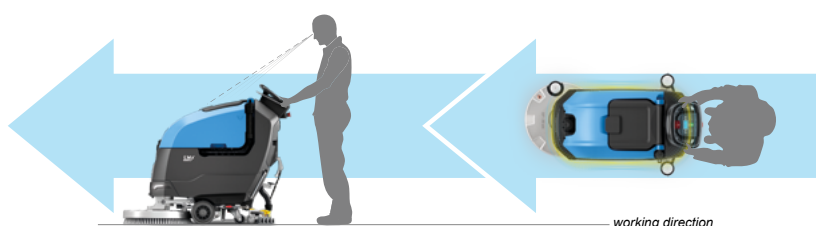



REGULATIONS

All references to forwards and backwards, front and rear, right and left indicated in this manual should be understood as referring to the operator in a driving position with his hands on the steering wheel.



 **N.B.:** in the image opposite with the arrow, forward gear is identified.

SYMBOLS USED IN THE MANUAL

	Open book symbol with an "i": Indicates the need to consult the instruction manual.
	Open book symbol: Tells the operator to read the user manual before using the device.
	Covered place symbol: The operations preceded by this symbol must always be carried out in a dry, covered area.
	Information symbol: Indicates additional information for the operator, to improve the use of the device.
	Warning symbol: Carefully read the sections preceded by this symbol meticulously following the instructions indicated for the safety of the operator and the device.
	Danger symbol (moving carriages): Indicates that the packed product should be handled with suitable carriages that conform to legal requirements.
	Symbol indicating the compulsory use of protective gloves: Indicates that the operator should always wear protective gloves, to avoid the risk of serious injury to his hands from sharp objects.
	Recycling symbol: Tells the operator to carry out the operations in compliance with environmental regulations in force in the place where the appliance is being used.
	Disposal symbol: Carefully read the sections marked with this symbol for disposing of the appliance.

TECHNICAL DESCRIPTION





This machine uses the mechanical action of a discoidal brush with the added action of a chemical solution applied to the brush via a water system.

The machine can clean a wide range of flooring and types of dirt, collecting, during its forward motion the dirt removed and the cleaning solution not absorbed by the floor. When the machine moves forward, the squeegee collects the dirt solution from the floor and the suction system transfers it to the recovery tank. **The machine must only be used for this purpose.**

INTENDED USE

This machine was designed and built for the cleaning (scrubbing and drying) of smooth, compact flooring in the commercial, residential and industrial sectors by a qualified operator in proven safety conditions.

 **IT IS FORBIDDEN** to use the machine for cleaning (scrubbing and drying) rugs or carpets.

 **WARNING** the machine is designed and built to be used only indoors or otherwise covered, it is not suitable for use in the rain or under jets of water.

 **IT IS FORBIDDEN** to use the machine in environments with an explosive atmosphere to clean dangerous powders or flammable liquids. In addition, it is not suitable as a means of transport for people or objects.

 **IT IS FORBIDDEN** to use the machine for purposes other than that for which it was built. This machine is designed and built for cleaning surfaces for professional and commercial use only; if it is used in other areas, the warranty will be invalidated.

SAFETY

Operator cooperation is paramount for accident prevention. No accident prevention programme can be effective without the full cooperation of the person directly responsible for machine operation. The majority of occupational accidents that happen either in the workplace or whilst moving are caused by failure to respect the most basic safety rules. An attentive, careful operator is most effective guarantee against accidents and is fundamental in order to implement any prevention programme.

SERIAL NUMBER PLATE

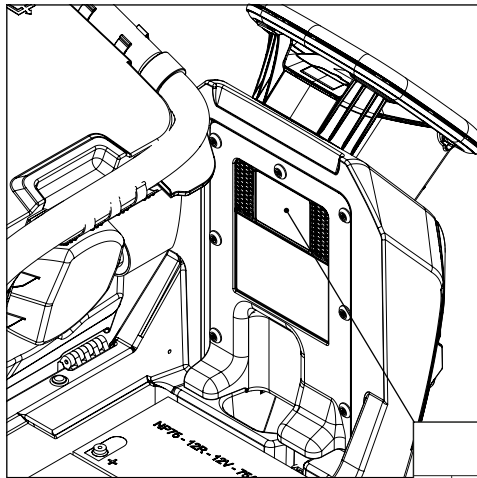

The serial number plate is positioned inside the machine, above the electrical system cover carter. It indicates the general machine characteristics, in particular the serial number. The serial number is a very important piece of information and should always be provided together with any request for assistance or when purchasing spare parts.

The serial number plate contains the following information:

1. The weight of the batteries that power the machine (expressed in kg).
2. The IP (International Protection) rating, which is a convention defined by the CEI EN 60529 standard ("Degrees of protection provided by enclosures") to identify the degree of protection of the enclosures of electrical and electronic devices against the penetration of external agents of a solid or liquid nature.

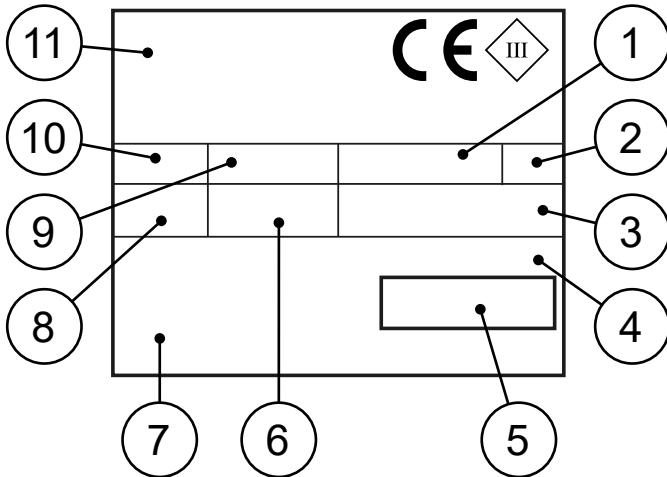

i N.B.: The IP rating is generally indicated by two characteristic digits plus two letters (additional and supplementary). The test to be performed is a visual verification of the machine's effective IPX3 protection from the conditions required by the product standard.

3. The GVW (Gross Vehicle Weight) in kg. See the TECHNICAL DATA chapter.

i N.B.: The technical data "GROSS VEHICLE WEIGHT" defines the gross weight of the machine ready for use.

4. The machine ID code.

5. The machine serial number.

i N.B.: the machine serial number is made up of nine figures:

- the first identifies the factory where the machine was manufactured
- the second and third correspond to the year of production (e.g. 23 indicates that the machine was produced in the year 2023)
- digits four to nine correspond to a progressive number

6. The value (in W) of the nominal power absorbed by the machine. See the TECHNICAL DATA chapter.

7. The machine ID name.

8.  The value (as %) of the maximum gradient the machine can handle while working. See the TECHNICAL DATA chapter.

9. The value (in V) of the nominal voltage used by the machine. See the TECHNICAL DATA chapter.

10. The year of machine manufacture.

11. The commercial name of the machine, and the manufacturer's address.

CE Corresponds to the CE marking symbol

i **N.B.:** the CE mark is a mark that must be affixed to certain types of products by the manufacturer itself, certifying conformity with the essential requirements for marketing and use in the European Union (EU) laid down in the so-called 'New Approach Directives'.

i **N.B.:** Fill in the following table at the time of delivery and/or installation, so it can be used as a future reference when necessary.

MACHINE ID NAME	
SERIAL NUMBER	
DATE OF DELIVERY AND/ OR INSTALLATION	

MAIN MACHINE COMPONENTS

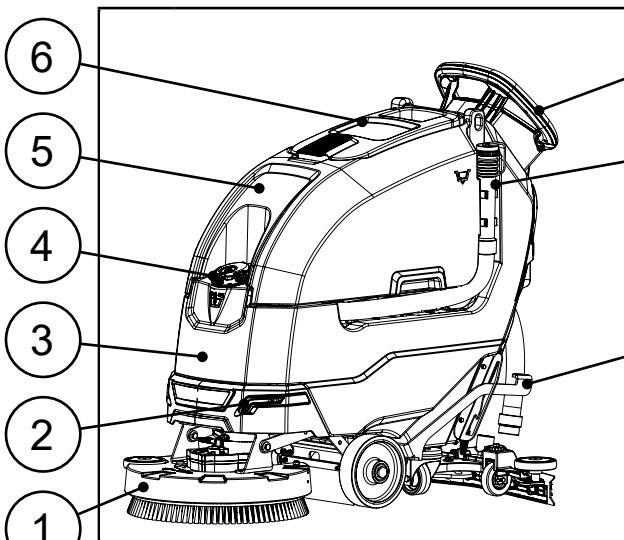

1	Scrubbing brush head
2	Front headlights (optional)
3	Solution tank
4	Solution tank inlet cap
5	Recovery tank
6	Recovery tank cover
7	Control handlebar
8	recovery tank drainage tube
9	Brush head control pedal

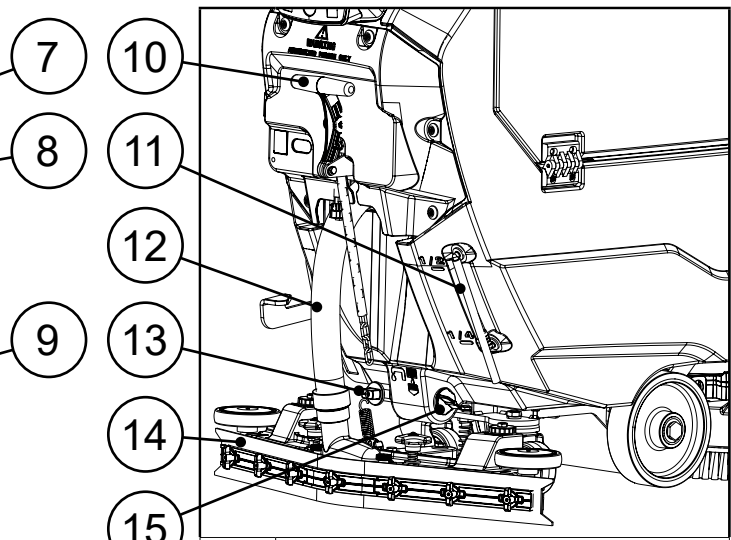

10	Squeegee control lever
11	Detergent solution level tube
12	Squeegee vacuum hose
13	Detergent solution flow adjustment tap
14	Squeegee
15	Solution tank cap-filter

TECHNICAL DATA

i **N.B.:** for any other technical data, contact your service centre of reference, or the one closest to you.

TECHNICAL DATA	IS of U.M. [International System]	JMX 43 B BASIC	JMX 43 B
Rated voltage [IEC 60335-2-72; IEC 62885-9]	V	24	24
Nominal input power [IEC 60335-2-72; IEC 62885-9]	KW	0,92	0,92
Working gradeability with GVW [IEC 60335-2-72; IEC 62885-9]	%	2	2
Machine working weight (gross weight - GVW) [IEC 60335-2-72; IEC 62885-9]	kg	147,7	147,7
Weight during transport [IEC 60335-2-72; IEC 62885-9]	kg	119,7	119,7
Machine dimensions during working phase (length; height width)	mm	1145 1000 705	1145 1000 705
Operator station sound pressure level (Lp _A) [IEC 60335-2-72; IEC 62885-9; ISO 11201]	dB (A)	61.5	61.5
Sound power level (Lw _A) [IEC 60335-2-72; IEC 62885-9; ISO 3744]	dB (A)	74,2	74,2
Uncertainty Kp _A	dB (A)	±1.5	±1.5
Hand-arm vibrations [IEC 60335-2-72; IEC 62885-9; ISO 5349-1]	m/s ²	0,8	0,8
Vibration measurement uncertainty		±4%	±4%

TECHNICAL DATA	SIB of U.M. [Imperial Measurement System]	JMX 43 B BASIC	JMX 43 B
Rated voltage [IEC 60335-2-72; IEC 62885-9]	V	24	24
Nominal input power [IEC 60335-2-72; IEC 62885-9]	KW	0,92	0,92
Working gradeability with GVW [IEC 60335-2-72; IEC 62885-9]	%	2	2
Machine working weight (gross weight - GVW) [IEC 60335-2-72; IEC 62885-9]	lb	325,62	325,62
Weight during transport [IEC 60335-2-72; IEC 62885-9]	lb	263,89	263,89
Machine dimensions during working phase (length; height width)	in	45,08 39,37 27,75	45,08 39,37 27,75
Operator station sound pressure level (Lp _A) [IEC 60335-2-72; IEC 62885-9; ISO 11201]	dB (A)	61.5	61.5
Sound power level (Lw _A) [IEC 60335-2-72; IEC 62885-9; ISO 3744]	dB (A)	74,2	74,2
Uncertainty Kp _A	dB (A)	±1.5	±1.5
Hand-arm vibrations [IEC 60335-2-72; IEC 62885-9; ISO 5349-1]	m/s ²	0,8	0,8
Vibration measurement uncertainty		±4%	±4%

TECHNICAL DATA	IS of U.M. [International System]	JMX 50 B BASIC	JMX 50 B
Rated voltage [IEC 60335-2-72; IEC 62885-9]	V	24	24
Nominal input power [IEC 60335-2-72; IEC 62885-9]	KW	0,92	0,92
Working gradeability with GVW [IEC 60335-2-72; IEC 62885-9]	%	2	2
Machine working weight (gross weight - GVW) [IEC 60335-2-72; IEC 62885-9]	kg	149,1	149,1
Weight during transport [IEC 60335-2-72; IEC 62885-9]	kg	121,1	121,1
Machine dimensions during working phase (length; height width)	mm	1185 1000 705	1185 1000 705
Operator station sound pressure level (Lp _A) [IEC 60335-2-72; IEC 62885-9; ISO 11201]	dB (A)	61.5	61.5
Sound power level (Lw _A) [IEC 60335-2-72; IEC 62885-9; ISO 3744]	dB (A)	74,2	74,2
Uncertainty Kp _A	dB (A)	±1.5	±1.5
Hand-arm vibrations [IEC 60335-2-72; IEC 62885-9; ISO 5349-1]	m/s ²	0,8	0,8
Vibration measurement uncertainty		±4%	±4%

TECHNICAL DATA	SIB of U.M. [Imperial Measurement System]	JMX 50 B BASIC	JMX 50 B
Rated voltage [IEC 60335-2-72; IEC 62885-9]	V	24	24
Nominal input power [IEC 60335-2-72; IEC 62885-9]	KW	0,92	0,92
Working gradeability with GVW [IEC 60335-2-72; IEC 62885-9]	%	2	2
Machine working weight (gross weight - GVW) [IEC 60335-2-72; IEC 62885-9]	lb	328,71	328,71
Weight during transport [IEC 60335-2-72; IEC 62885-9]	lb	266,98	266,98
Machine dimensions during working phase (length; height width)	in	45,08 39,37 27,75	45,08 39,37 27,75
Operator station sound pressure level (Lp _A) [IEC 60335-2-72; IEC 62885-9; ISO 11201]	dB (A)	61.5	61.5
Sound power level (Lw _A) [IEC 60335-2-72; IEC 62885-9; ISO 3744]	dB (A)	74,2	74,2
Uncertainty Kp _A	dB (A)	±1.5	±1.5
Hand-arm vibrations [IEC 60335-2-72; IEC 62885-9; ISO 5349-1]	m/s ²	0,8	0,8
Vibration measurement uncertainty		±4%	±4%

SYMBOLS USED ON THE MACHINE

Solution tank filling level symbol:
 Located on the rear right part of the machine's solution tank, to indicate the amount of detergent solution in the tank.

Position symbol for the brush head control pedal:
 Located on the rear left part of the solution tank, to identify the brush head control pedal (on basic versions).

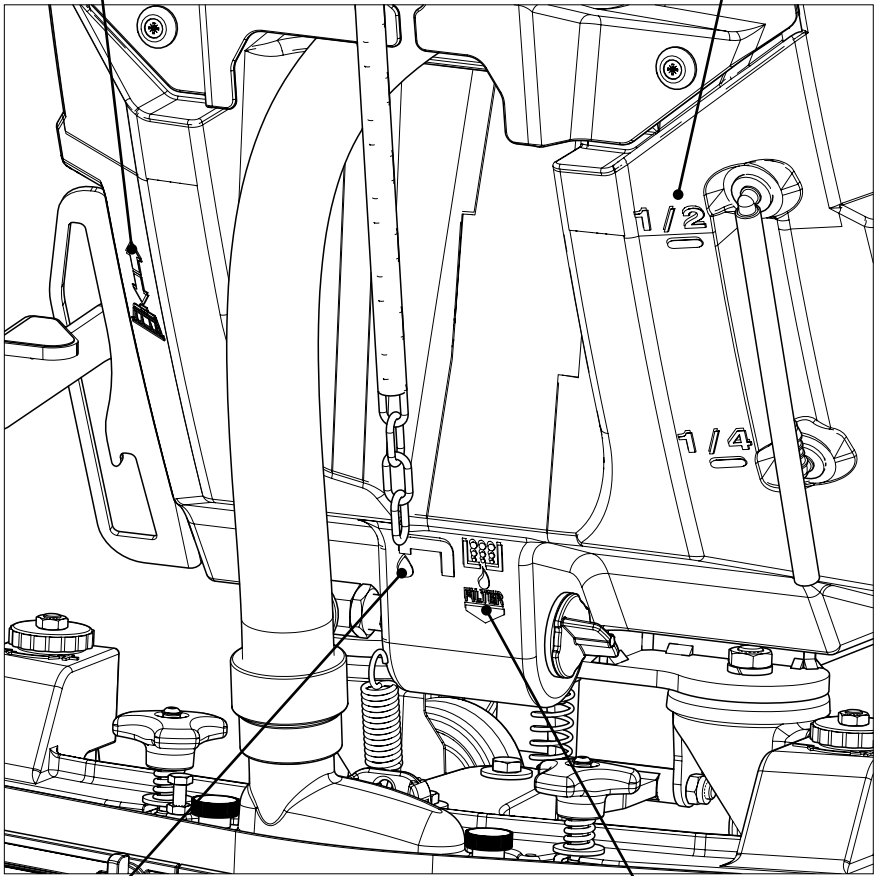

Position symbol for the detergent solution adjusting tap:
 It is used at the back of the solution tank to identify the detergent solution adjustment knob.

Position symbol for the solution tank cap - filter:
 It is used in the back of the solution tank to identify the solution tank cap - filter.

Solution tank filling temperature symbol:

Located on the front part of the solution tank, to indicate the maximum temperature of the water for filling the solution tank safely.

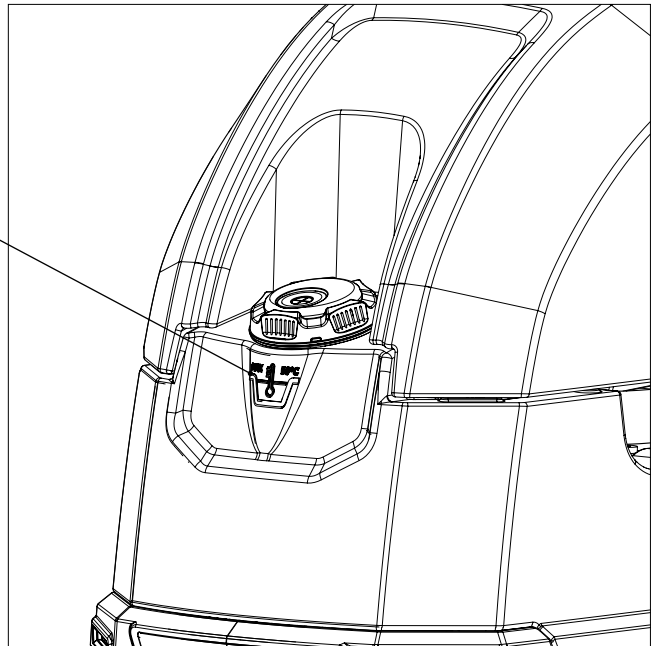

Recovery tank drainage hose symbol:

Located on the left side of the recovery tank, to identify the recovery tank drainage hose.

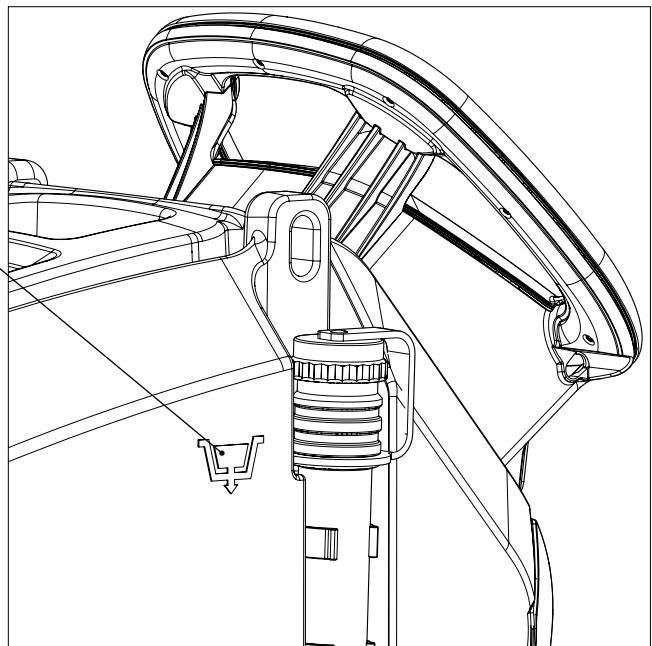

Warning symbol removal only by authorised personnel:

Located on the electrical system cover carter, to warn the operator that the carter must only be removed by service centre personnel.

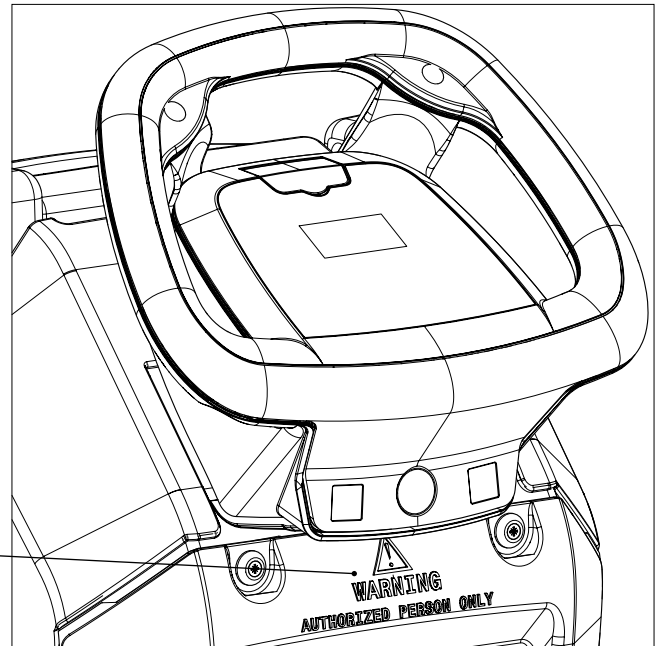

LABELS USED ON THE MACHINE



Do not go next to the brush head while the brush is moving.

Label indicating that touching the brush when moving is prohibited:

It is used to indicate to the operator that it is forbidden to approach the brush with the hands while it is in motion.

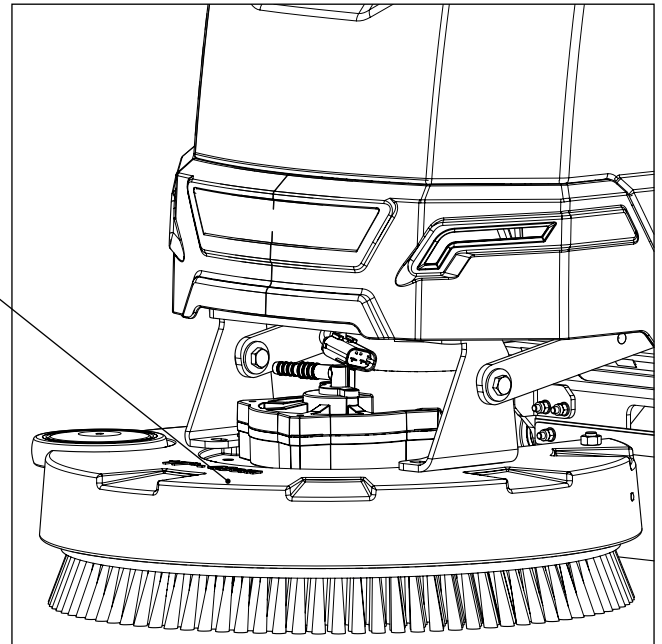

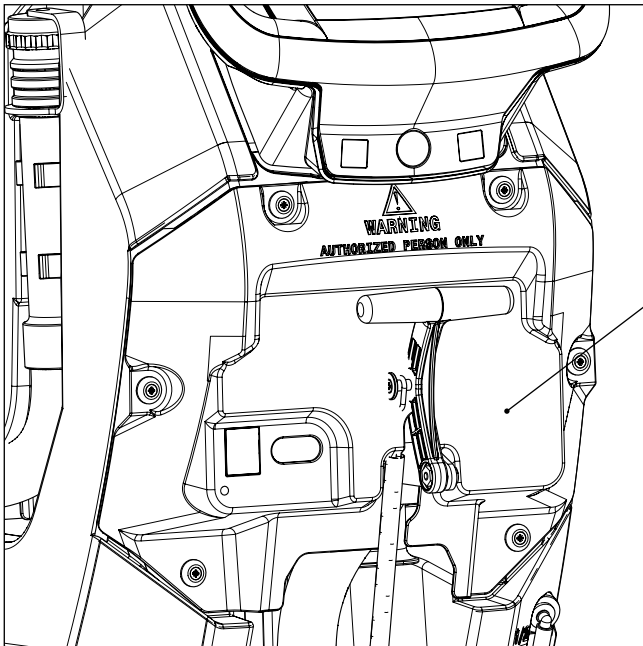

Battery charging instruction label:
 Informs the user about the procedures for recharging the batteries correctly.

Daily maintenance label:
 Reminds the user to turn off the tap at the end of the work, and to carry out daily maintenance on all the machine filters.

Prohibition to vacuum hazardous elements label:
 Informs the user that it is strictly forbidden to pick up white-hot particles or flammable and/or explosive dust and/or liquids with the machine, and to work nearby.

Label indicating the need to see the Use and Maintenance Manual:
 Indicates the need to see the use and maintenance manual before using the machine.

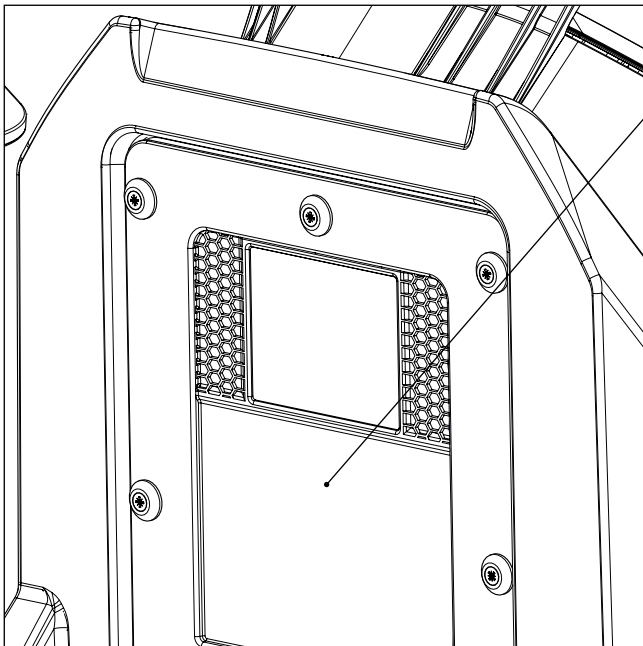

Battery warning label:
 Informs the user that highly flammable hydrogen gas may escape from the cells during the charging phase. See the GENERAL SAFETY REGULATIONS document included with the machine documentation.

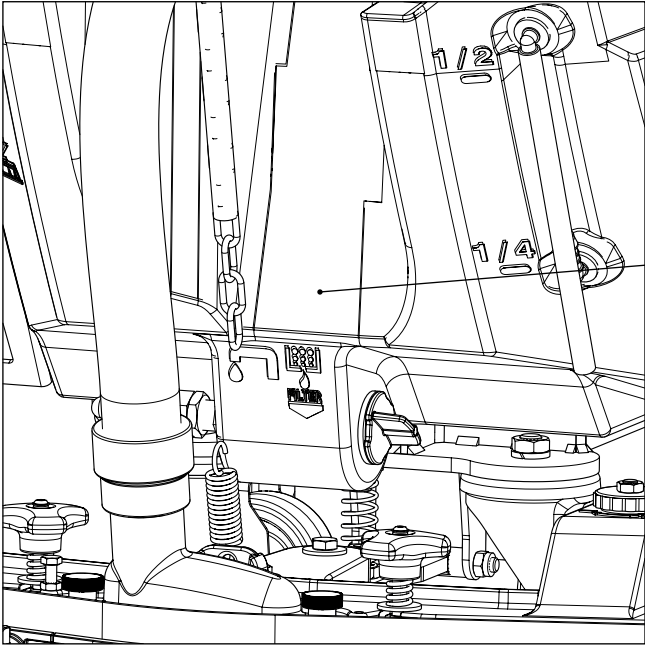

Water system filter maintenance warning label:

Warns the user of the need to service the water system filter every time the machine is used.

- Pulire sempre il filtro del serbatoio soluzione dopo ogni uso
- Clean the solution tank filter after every use
- Limpiar el filtro del tanque solución después de cada uso
- Nettoyer toujours le filtre du réservoir solution après chaque usage
- Reinigungsbehälter immer nach jeder Benutzung säubern

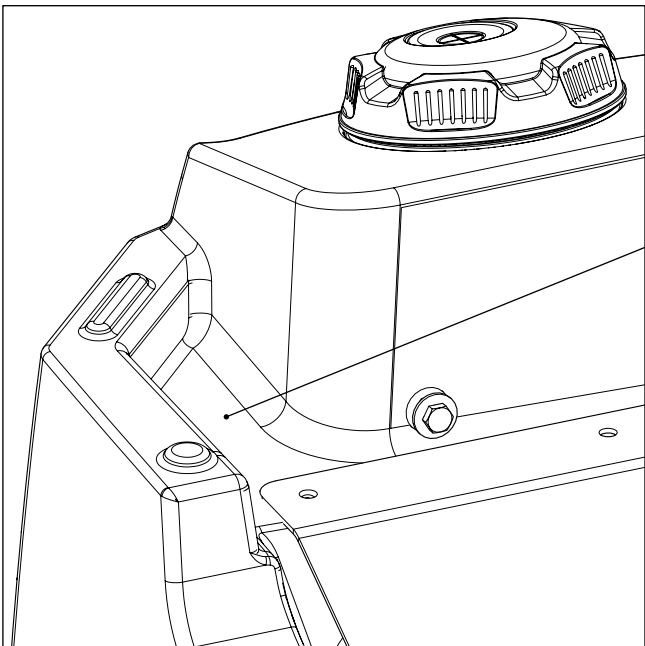

Label warning about the risk of crushed hands:

Applied to the solution tank to indicate the areas where hand crushing hazards are present.

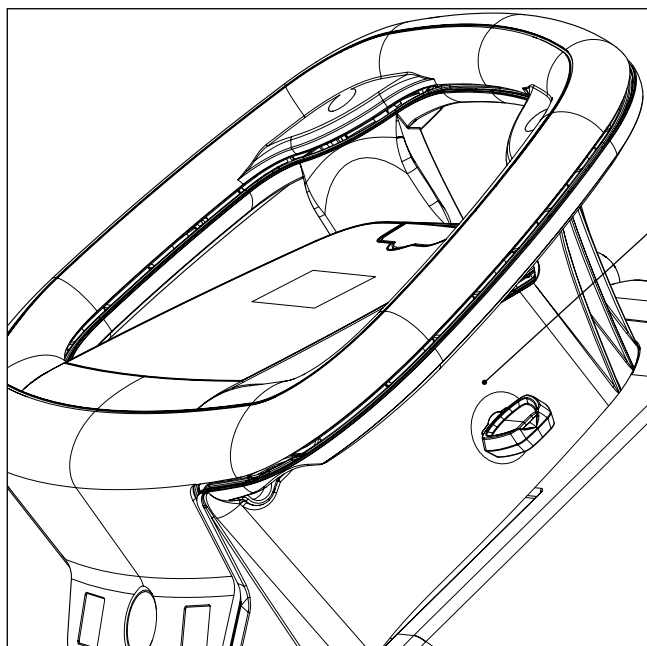

Label for ON-OFF key switch:
It is used to identify the position of the key switch to the user.

CONTROL STATION

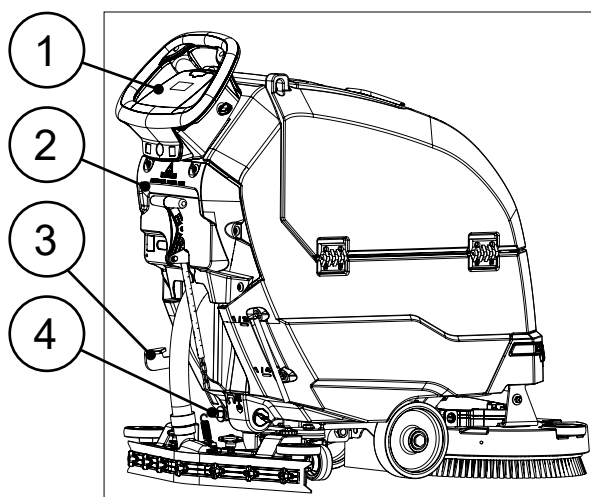

The machine has an easy and user-friendly control station, comprised of mainly the following:

1. Control panel.
2. Squeegee support control lever.
3. Brush head control pedal (basic versions).
4. Detergent solution regulation tap.

DASHBOARD

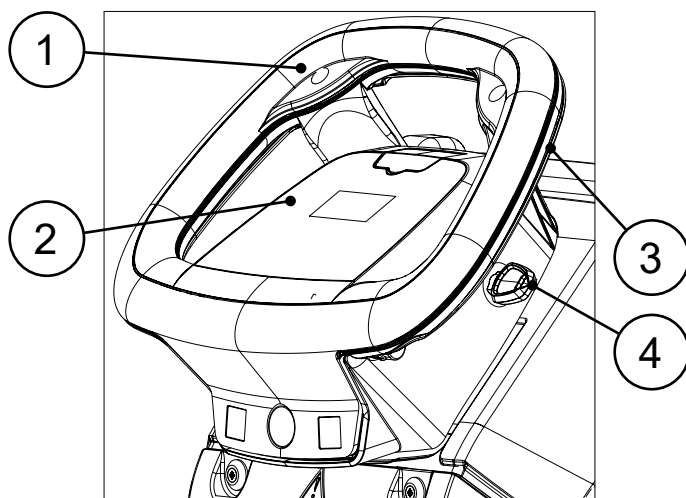

The basic control panel with traction, on battery-powered versions, consists mainly of the following:

1. Control handlebars.
2. Control display.
3. "Dead man's" lever (valid for PRO versions).
4. Main key switch.

CONTROL DISPLAY

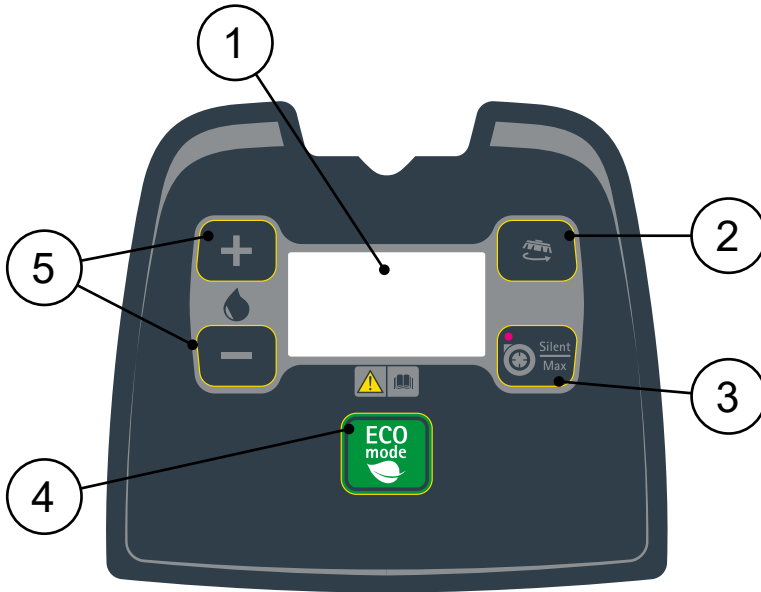

Basic version

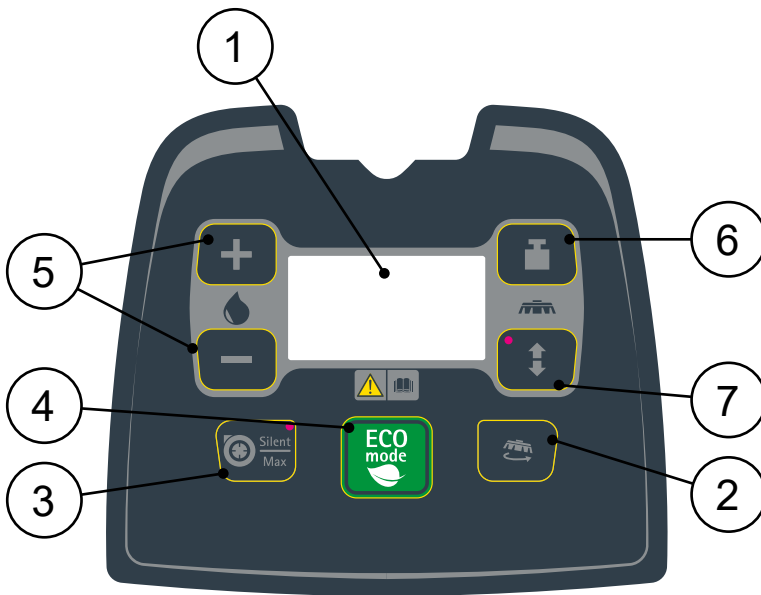

Pro version

The control panel is subdivided as follows:

1. Control display. See the "CONTROL DISPLAY" paragraph.
2. Brush uncoupling control button. See the "BRUSH UNCOUPLING FUNCTION" paragraph.
3. Squeegee noiseless suction control button. See the "NOISELESS SUCTION" paragraph.
4. ECO MODE working program control button. See the "ECO MODE WORKING PROGRAM" paragraph.
5. Detergent solution performance adjustment buttons. See the "REGULATING THE FLOW OF DETERGENT SOLUTION" paragraph.
6. Extra brush head pressure control button. See the "REGULATING THE EXTRA BRUSH HEAD PRESSURE" paragraph (valid for PRO versions).
7. Brush head control button (valid for the PRO version).

CONTROL DISPLAY

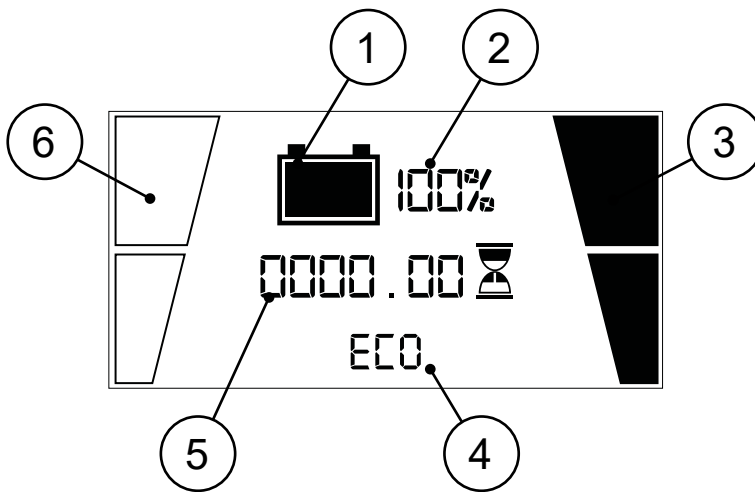

The control display consists of the following:

1. Graphic symbol used to identify the residual battery charge. See the "BATTERY CHARGE LEVEL INDICATOR" paragraph.
2. Numeric symbol showing the residual battery charge percentage. See the "BATTERY CHARGE LEVEL INDICATOR" paragraph.
3. Graphical symbol used to identify the level of pressure exerted on the brush head. See the "REGULATING THE PRESSURE EXERTED ON THE BRUSH HEAD" (valid for PRO versions).
4. Graphic symbol indicating that the "ECO" working program is active. See the "ECO MODE WORKING PROGRAM" paragraph.
5. Numeric symbol used to identify the machine hour meter. See the "HOUR METER (BATTERY-POWERED PRO VERSIONS)" paragraph.
6. Graphic symbol used to indicate the detergent solution performance level. See the "REGULATING THE DETERGENT SOLUTION FLOW" paragraph.

PREPARATION OF MACHINE

HANDLING THE PACKAGED MACHINE

The overall dimensions of the entire package are:

JMX PACKAGE	IS of U.M. [International System]	SIB of U.M. [Imperial Measurement System]
Length	143cm	56.30in
Width	66cm	25.98in
Height	117cm	46.06in

The weight of the packaging is: 95kg (209.44lb)

N.B.: it is recommended that all the packaging components be kept for any future machine transportation.

DANGER: Handle the packaged product with handling trolleys that comply with the load handling guidelines in force in the country of use, and with the dimensions and mass of the package itself.

HOW TO UNPACK THE MACHINE

How to unpack the machine (basic versions):

The machine is shipped in specific packaging. To remove it, proceed as follows:

1. Place the lower part of the outer packaging in contact with the floor.

 **N.B.:** use the pictograms printed on the box as a reference.

2. Remove the outer package.

 **WARNING:** the machine is contained in specific packaging materials, whose elements (plastic bags, staples, etc.) can pose potential hazards, and must not be left within reach of children, disabled persons, etc.

3. Remove the boxes containing the disc brushes and squeegee body from the machine.

 **CAUTION:** it is recommended to wear the appropriate PPE (Personal Protective Equipment), suitable for the work to be carried out.

4. Place a descent ramp at the rear of the machine.

 **WARNING:** the ramp must have a suitable slope and load-bearing capacity to avoid any damage to the machine or to the ramp itself when the machine moves across it.

5. The machine is secured to the footboard with wedges that lock the wheels; remove these wedges.
6. Bring the brush head to the maintenance position (raised off the floor), pressing the pedal all the way down and then shifting it to the right before releasing it so it cannot be moved.
7. Bring the squeegee support to the maintenance position (raised off the floor), rotating the squeegee control lever upwards.
8. Turn the main machine switch to "0", turn the key a quarter turn counter-clockwise.
9. Remove the key from the instrument panel.

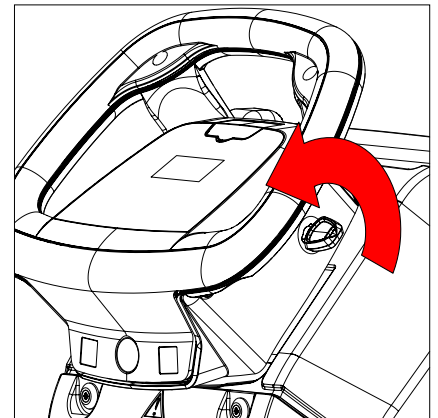
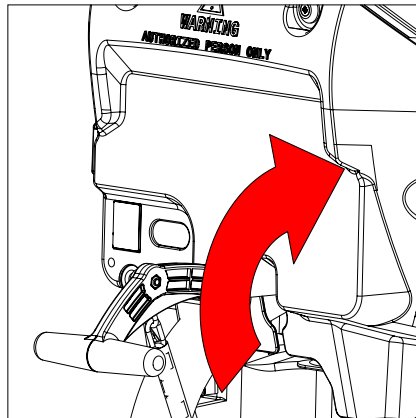
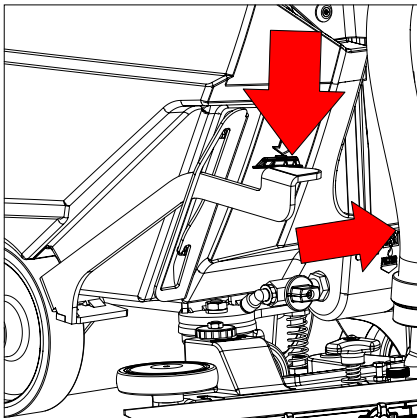

10. Drive the machine down the ramp.

 **WARNING:** the descent ramps are consigned in the machine packaging. If there are no ramps provided, bear in mind the one used must have a suitable slope to avoid damaging the machine and a sufficient load-bearing capacity to ensure it does not break when the machine moves across it.

 **ATTENTION:** during this operation, check there are no people or objects near the machine.

How to unpack the machine (pro versions):

The machine is shipped in specific packaging. To remove it, proceed as follows:

1. Place the lower part of the outer packaging in contact with the floor.

i **N.B.:** use the pictograms printed on the box as a reference.

2. Remove the outer package.

! **WARNING:** the machine is contained in specific packaging materials, whose elements (plastic bags, staples, etc.) can pose potential hazards, and must not be left within reach of children, disabled persons, etc.

3. Remove the boxes containing the disc brush and squeegee body from the machine.

! **CAUTION:** it is recommended to wear the appropriate PPE (Personal Protective Equipment), suitable for the work to be carried out.

4. Place two descent ramps at the rear of the machine.
5. The machine is secured to the footboard with wedges that lock the wheels; remove these wedges.
6. Turn the main machine switch to "0", turn the key a quarter turn counter-clockwise.
7. Remove the key from the instrument panel.
8. Using the handle on the recovery tank, turn it to the maintenance position.

! **ATTENTION:** the following operations must be carried out by qualified personnel. An incorrect connection of the connector may cause a malfunction of the device.

9. Connect the connector of the battery pad trolley to the machine's main system connector.
10. Rotate the recovery tank into the work position.
11. Stand at the back of the machine.
12. Insert the key in the main switch on the instrument panel.
13. Turn the main machine switch to "I", making a quarter turn clockwise with the key.

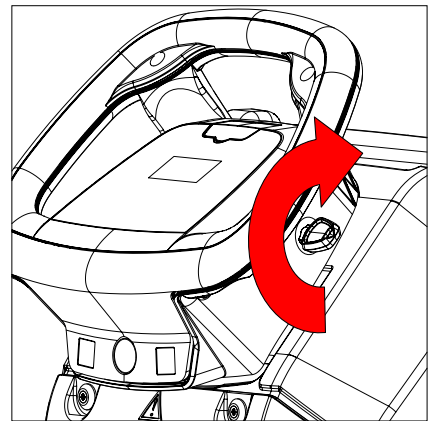
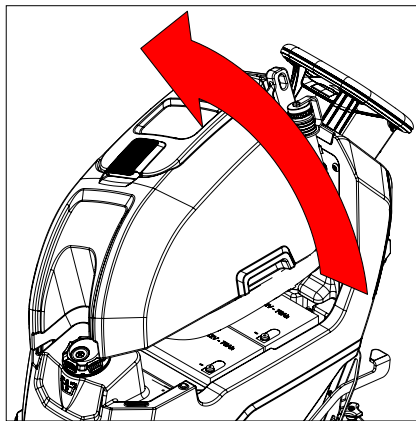
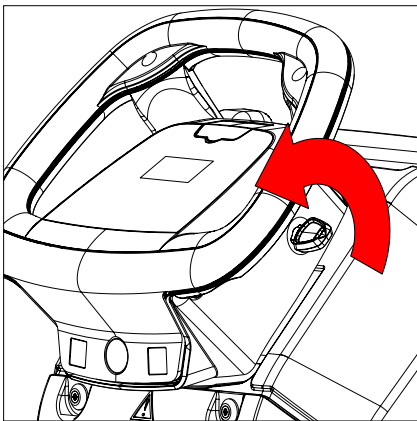

i **N.B.:** at switch-on, the control display visualises a series of pages, the last of which shows the machine programming characteristics. See the "STARTING WORK" chapter.

14. Bring the brush head to the maintenance position (raised off the floor) by pressing the brush head control button  on the control panel.

i **N.B.:** when the brush head is in the maintenance position, the LED in the button is OFF.

15. Bring the squeegee to the maintenance position (raised off the floor) by rotating the squeegee control lever upwards.

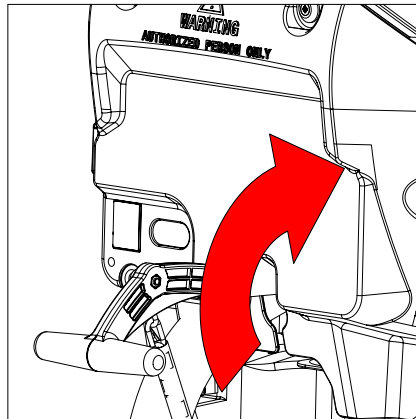

16. Drive the machine down the ramp.

WARNING: the descent ramps are consigned in the machine packaging. If there are no ramps provided, bear in mind the one used must have a suitable slope to avoid damaging the machine and a sufficient load-bearing capacity to ensure it does not break when the machine moves across it.

ATTENTION: during this operation, check there are no people or objects near the machine.

17. Turn the main machine switch to "0", turn the key a quarter turn counter-clockwise.

18. Remove the key from the instrument panel.

19. Grip the handle and turn the recovery tank to its maintenance position.

ATTENTION: the following operations must be carried out by qualified personnel. An incorrect connection of the connector may cause a malfunction of the device.

20. Disconnect the backup battery trolley connector from the main machine system connector.

21. Grip the handle and turn the recovery tank to its working position.

MACHINE SAFETY

Machine safety (basic versions):

To ensure that work is carried out in the best safety conditions, proceed as follows:

CAUTION: it is recommended to wear the appropriate PPE (Personal Protective Equipment), suitable for the work to be carried out.

1. Make sure the recovery tank is empty. If it isn't, empty it. See the "EMPTYING THE RECOVERY TANK" paragraph.
2. Make sure the solution tank is empty. If it isn't, empty it. See the "EMPTYING THE SOLUTION TANK" paragraph.
3. Stand at the back of the machine.
4. Turn the main machine switch to "0", turn the key a quarter turn counter-clockwise.
5. Remove the key from the instrument panel.
6. Bring the brush head to the maintenance position (raised off the floor), pressing the pedal all the way down and then shifting it to the right before releasing it so it cannot be moved.
7. Bring the squeegee to the maintenance position (raised off the floor) by rotating the squeegee control lever upwards.

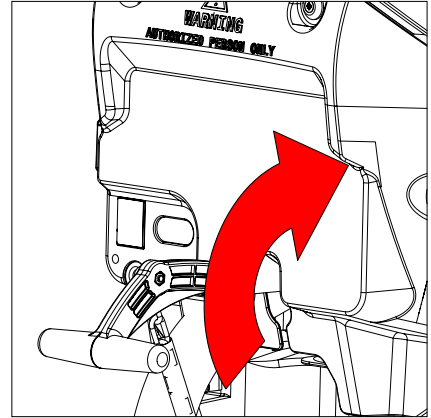
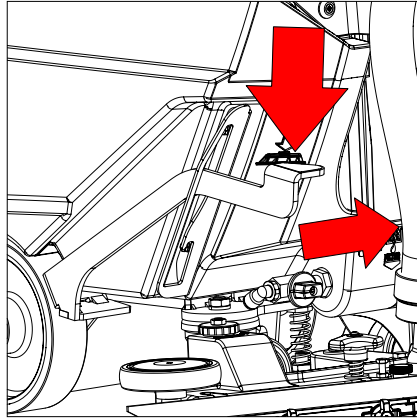
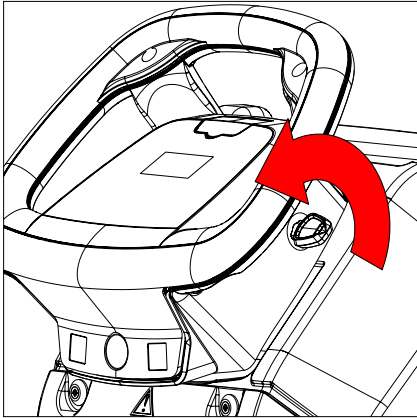

8. Using the handle on the recovery tank, turn it to the maintenance position.

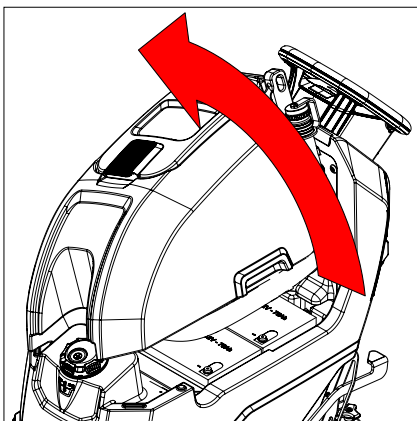

⚠ ATTENTION: to prevent the recovery tank from rotating accidentally, turn it until the retainer cable is fully tensioned.

⚠ ATTENTION: the following operations must be carried out by qualified personnel. Incorrect operations could result in machine malfunctions.

9. Disconnect the connector on the machine's electrical system wiring from the connector on the power cable from the battery box.

10. Using the handle on the recovery tank, turn it to the working position.

Machine safety (pro versions):

To ensure that work is carried out in the best safety conditions, proceed as follows:

🧤 CAUTION: it is recommended to wear the appropriate PPE (Personal Protective Equipment), suitable for the work to be carried out.

1. Make sure the recovery tank is empty. If it isn't, empty it. See the "EMPTYING THE RECOVERY TANK" paragraph.
2. Make sure the solution tank is empty. If it isn't, empty it. See the "EMPTYING THE SOLUTION TANK" paragraph.
3. Stand at the back of the machine.
4. Insert the key in the main switch on the instrument panel.
5. Turn the main machine switch to "I", turn the key a quarter turn clockwise.

📘 N.B.: at switch-on, the control display visualises a series of pages, the last of which shows the machine programming characteristics. See the "STARTING WORK" chapter.

6. Bring the brush head to the maintenance position (raised off the floor) by pressing the brush head control button  on the control panel.

📘 N.B.: when the brush head is in the maintenance position, the LED in the button is OFF.

7. Bring the squeegee to the maintenance position (raised off the floor) by rotating the squeegee control lever upwards.

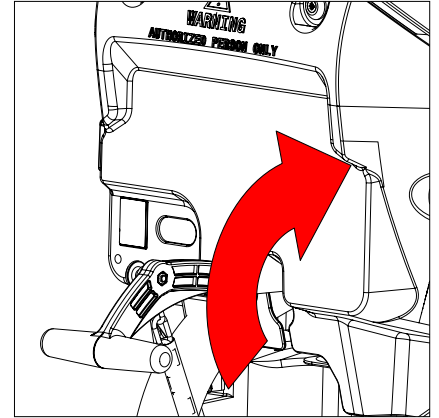
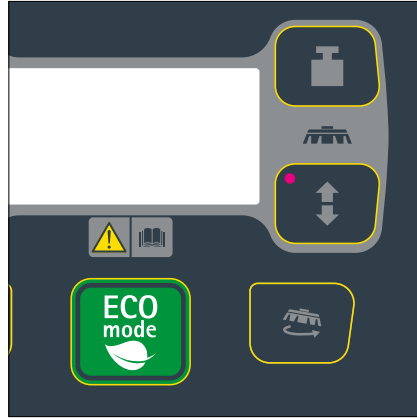
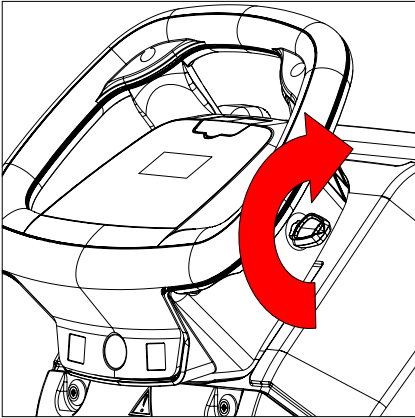

8. Turn the main switch to "0", making a quarter turn anti-clockwise with the key.
9. Remove the key from the instrument panel.
10. Using the handle on the recovery tank, turn it to the maintenance position.

⚠ ATTENTION: to prevent the recovery tank from rotating accidentally, turn it until the retainer cable is fully tensioned.

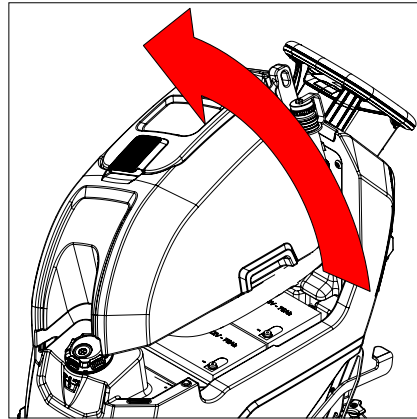
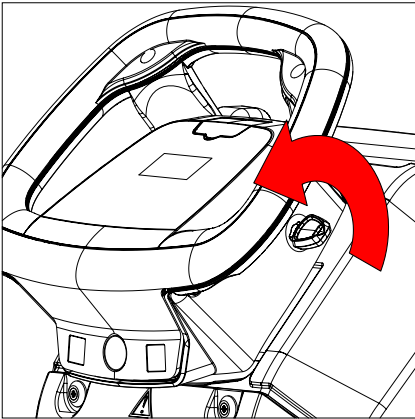

⚠ ATTENTION: the following operations must be carried out by qualified personnel. Incorrect operations could result in machine malfunctions.

11. Disconnect the connector on the machine's electrical system wiring from the connector on the power cable from the battery box.
12. Using the handle on the recovery tank, turn it to the working position.

HOW TO MOVE THE MACHINE

The procedure for transporting the machine full safely is as follows:

🧤 CAUTION: it is recommended to wear the appropriate PPE (Personal Protective Equipment), suitable for the work to be carried out.

1. Carry out all the operations required to put the machine in a safe condition. See the "MACHINE SAFETY" paragraph.
2. Use a ramp to move the machine up onto the transport vehicle.

⚠ CAUTION: during this operation, check there are no people or objects near the machine.

📄 N.B.: the ramp gradient must not be such as to cause damage to the machine.

- Place the machine on the transport vehicle.
- Secure the machine to the means of transport using an appropriate number and type of fastening elements, based on its weight and size.

CAUTION: secure the machine according to the directives in force in the country of use, so that it cannot slide or tip over.

TYPE OF BATTERY TO BE USED

Battery type	Voltage (V)	Work (Ah _{CS})
NP 75-12 R (AGM)	12	75
LFP 24V 30Ah (Li-Ion)	24	30
LFP 24V 54Ah (Li-Ion)	24	54

For good working performance, the machine must be powered at 24V, here are the three types of batteries that FIMAP offers to its customers.

FIMAP recommends the use of AGM 12V 75_{CS} batteries.

The dimensions of the battery holder compartment are: 350x240x270 mm (length x height x width).

The function board in the machine is factory-programmed to work with the following type of battery: Gel60. To change the selected battery type, contact your service centre of reference or the one closest to you.

BATTERY MAINTENANCE AND DISPOSAL

For battery maintenance and recharging, follow the instructions contained in the document provided by the battery manufacturer.

When the batteries are dead, they must be disconnected by a specialised technician from the machine manufacturer's service centre of reference. Handle the batteries with lifting devices suitable for their size and weight; take them to a suitable disposal centre.

N.B.: used batteries, which are classified as hazardous waste, must be returned to a legally authorised waste disposal authority.

INSERTING THE BATTERIES IN THE MACHINE

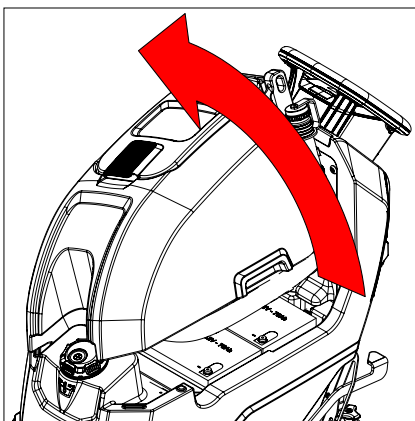

The batteries must be inserted in the machine by a specialised technician from the machine manufacturer's service centre of reference.

WARNING: the manufacturer disclaims all responsibility for any damage to property or injury to persons in the event that the batteries are replaced by an unauthorised technician.

CAUTION: it is recommended to wear the appropriate PPE (Personal Protective Equipment), suitable for the work to be carried out.

To insert the batteries in the machine, proceed as follows:

- Carry out all the operations required to put the machine in a safe condition. See the "MACHINE SAFETY" paragraph.
- Using the handle on the recovery tank, turn it to the maintenance position.

ATTENTION: to prevent the recovery tank from rotating accidentally, turn it until the retainer cable is fully tensioned.

ATTENTION: the following operations must be carried out by qualified personnel. Incorrect operations could result in machine malfunctions.

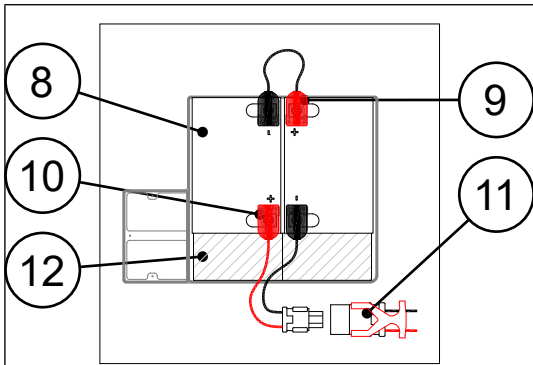

Placement of AGM batteries 12-NP-75: place the batteries (8) in the relevant compartment, with the '+' and '-' poles facing each other. Use the jumper cable (9) to connect the two batteries (8) so that the voltage is 24V. Connect the battery cable (10) to the remaining free poles. Connect the male connector on the machine cable (11) to the female connector on the battery system cable (10).

i N.B.: to prevent the batteries from moving, place the spacers inside the battery compartment as well (12).

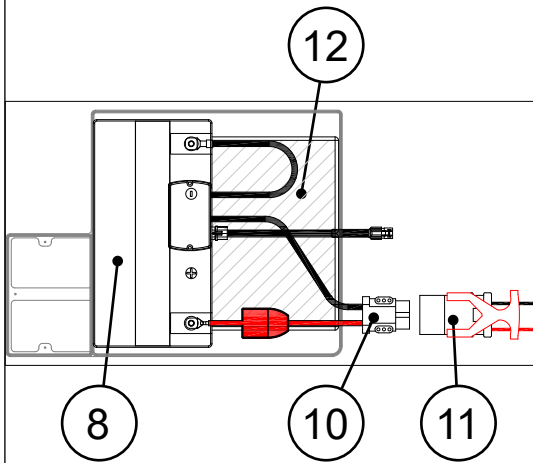

Placement of Li-ion 24V 30Ah batteries: place the battery (8) in the battery compartment. Connect the battery cable (10) to the poles in the battery. Connect the male connector on the machine cable (11) to the female connector on the battery system cable (10).

i N.B.: to prevent the battery from moving, also place the spacers (12) inside the battery compartment.

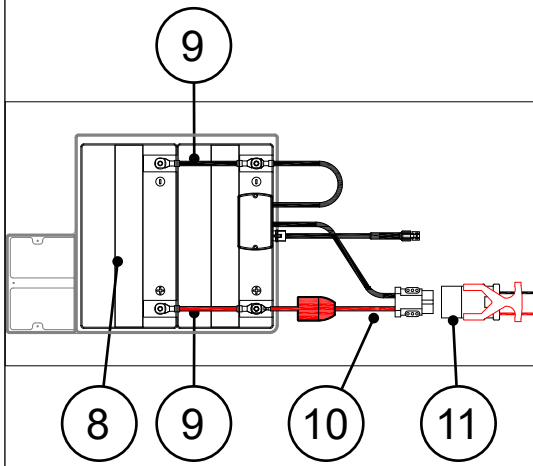

Placement of Li-ion 24V 54Ah batteries: place the batteries (8) in the battery compartment, with the '+' and '-' poles parallel to each other. Use the bridge cable (9) to connect the two batteries (8) so that they have a nominal current of 100Ah. Connect the battery cable (10) to the poles in the battery. Connect the male connector on the machine cable (11) to the female connector on the battery system cable (10).

⚠ ATTENTION: the positive pole of the battery must always be connected to the red cable and the negative pole to the black cable.

RECHARGING THE BATTERIES

The batteries must be charged prior to first use and whenever they no longer provide sufficient power for the job to be carried out.

WARNING: the function board in the machine is programmed by the factory to work with the following type of battery: Gel60. To change the battery type, contact a technician from your service centre of reference.

N.B.: before recharging, carefully see the Use and Maintenance Manual of the batteries you want to use.

1. Bring the machine to the battery recharging area.

ATTENTION: Park the machine in an enclosed place, on a flat and level surface; near the machine there must be no objects that could either damage it, or be damaged through contact with it.

ATTENTION: the room where the batteries are recharged must be adequately ventilated to prevent the accumulation of gases that leak from batteries.

WARNING: the place designated for this operation must comply with current regulations concerning safety at work and current environmental protection regulations.

CAUTION: it is recommended to wear the appropriate PPE (Personal Protective Equipment), suitable for the work to be carried out.

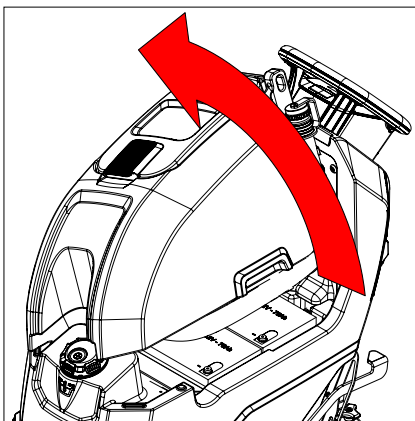

2. Carry out all the operations required to put the machine in a safe condition. See the "MACHINE SAFETY" paragraph.
3. Using the handle on the recovery tank, turn it to the maintenance position.

ATTENTION: to prevent the recovery tank from rotating accidentally, turn it until the retainer cable is fully tensioned.

ATTENTION: the following operations must be carried out by specialised personnel from the service centre of reference. Incorrect connection of the connector can cause machine malfunctions.

How to recharge the batteries with an external battery charger:

N.B.: the connector to be wired into the battery connection cable is delivered in the bag containing this instruction booklet and must be fitted in accordance with the instructions.

ATTENTION: Before connecting the batteries to the battery charger, make sure it is suitable for the batteries you want to use.

N.B.: before recharging, carefully see the Use and Maintenance Manual of the battery charger you want to use.

1. Disconnect the connector on the battery cable from the connector on the machine's electrical system cable.
2. Connect the connector on the battery cable to the connector on the battery charger cable.

CAUTION: keep the recovery tank open for the duration of the battery box charging cycle to allow gas fumes to escape.

3. Read the battery charger manual to carry out the charging cycle.

4. When the recharging cycle has finished, disconnect the connector on the battery cable from the connector on the battery charger cable.
5. Connect the connector on the battery cable to the connector on the machine's electrical system cable.
6. Go to the side of the machine, then grip the handle and turn the recovery tank to its working position.

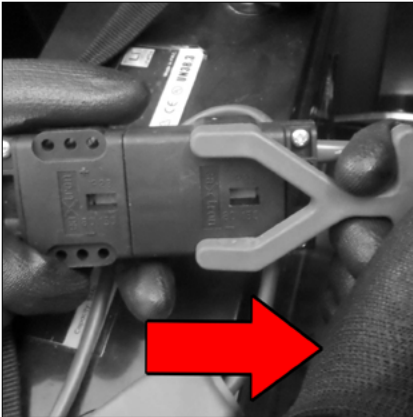

How to recharge the batteries with a built-in battery charger:

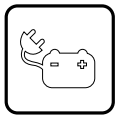

The on-board battery charger ensures maximum performance because it has been specially selected for the scrubbing machine on which it is mounted. The on-board battery charger offers the great convenience of being able to recharge the machine wherever you are at the end of your shift, without necessarily having to return to a specific point on the route.

⚠ WARNING: before carrying out the battery charging cycle, check that the battery charger is suitable for the batteries you want to use. The battery charger in the machine is programmed by the factory with the following type of charging curve: General Gel. To change the type of charging curve, contact your service centre of reference or the one closest to you.



N.B.: carefully see the use and maintenance manual for the battery charger delivered in the bag containing this instruction manual.

1. Connect the battery charger power cable plug to the mains socket.
2. Go to the back of the machine and remove the cap from the battery charger socket.
3. Connect the connector on the battery charger supply cable to the socket on the battery charger.

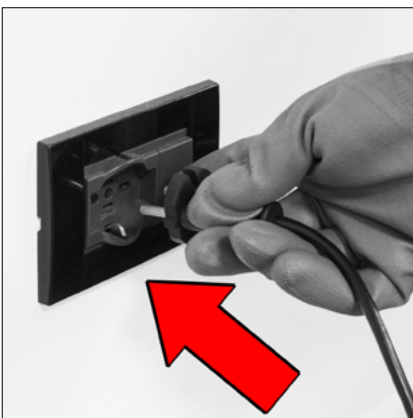

⚠ WARNING: before inserting the battery charger power cable in the socket, make sure there is no condensation or any other type of liquid.



N.B.: the battery charger power cable is delivered inside the bag containing this instruction booklet.

CAUTION: keep the recovery tank open for the duration of the battery box charging cycle to allow gas fumes to escape.

WARNING: if the LEDs on the battery charger display make a series of non-compliant flashes during the battery charging phase, stop the charging and contact your service centre of reference.

4. When the charging cycle has finished, disconnect the connector on the battery charger supply cable from the socket on the battery charger.
5. Disconnect the battery charger supply cable plug from the mains socket.
6. Go to the back of the machine and refit the cap on the battery charger socket.

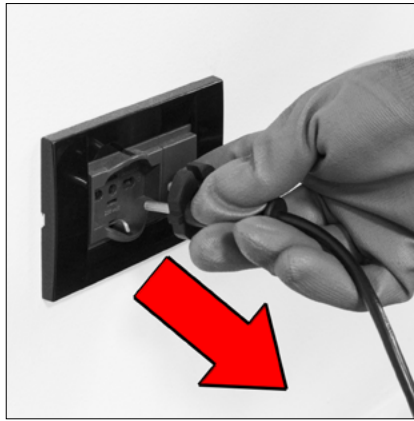
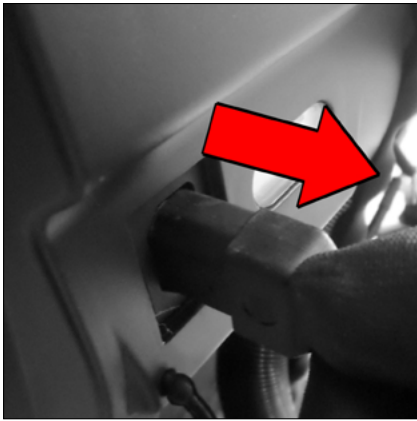

7. Using the handle on the recovery tank, turn it to the working position.

INSERTING WATER SYSTEM FILTER

Before using the machine for the first time, the water system filter must be put back in place (having been removed from the machine for shipping purposes).

To insert the filter cap into the solution tank:

1. Take the machine to the maintenance area.

WARNING: the place designated for this operation must comply with current regulations concerning safety at work and current environmental protection regulations.

2. Carry out all the operations required to put the machine in a safe condition. See the "MACHINE SAFETY" paragraph.

CAUTION: it is recommended to wear the appropriate PPE (Personal Protective Equipment), suitable for the work to be carried out.

3. Tighten the tap outlet flow, turning the knob on the rear of the machine clockwise.
4. Screw the cap onto the solution tank.

N.B.: before screwing the cap onto the solution tank, insert the gasket in its seat in the cap.

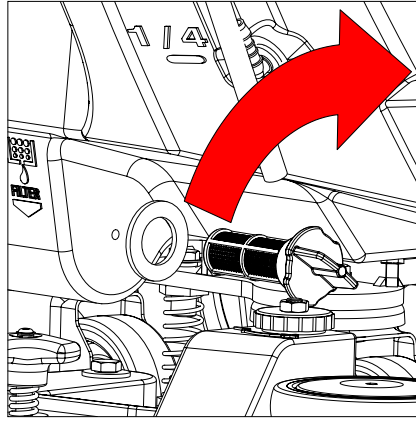
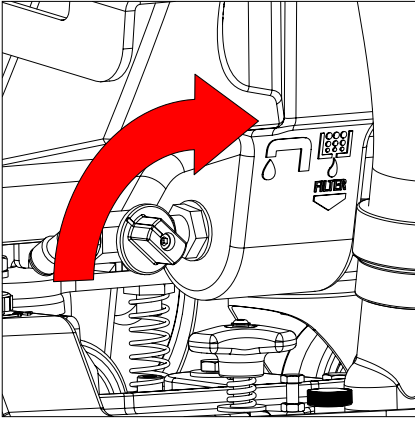

FILLING THE SOLUTION TANK

Proceed as follows to fill the solution tank with water:

1. Take the machine to the place designated for filling the solution tank.

WARNING: the place designated for this operation must comply with current regulations concerning safety at work and current environmental protection regulations.

2. Carry out all the operations required to put the machine in a safe condition. See the “MACHINE SAFETY” paragraph.

CAUTION: it is recommended to wear the appropriate PPE (Personal Protective Equipment), suitable for the work to be carried out.

3. Tighten the tap outlet flow, turning the knob on the rear of the machine clockwise.
4. Make sure the filter cap at the rear of the machine is tightened; if it isn't, turn it clockwise.
5. Remove the cap from the solution tank inlet.

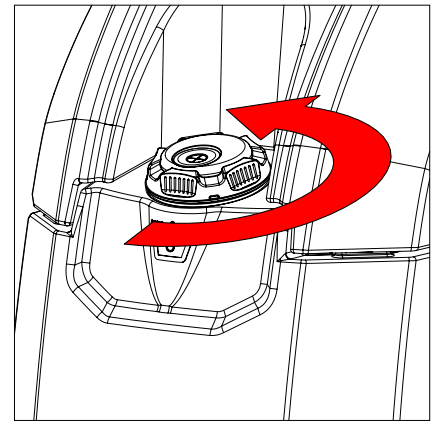
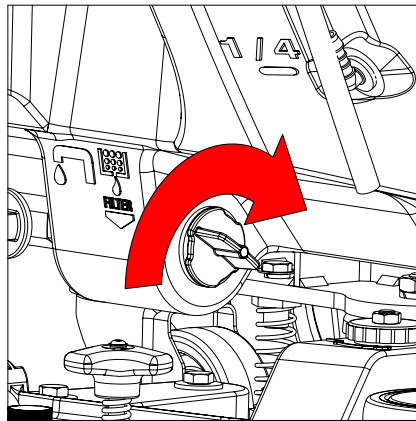
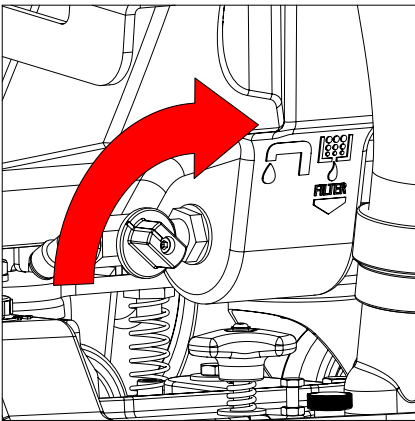

6. Make sure the filter under the cap is positioned correctly to prevent impurities and dirt from causing the machine's water system to malfunction.
7. Fill the solution tank.

N.B.: you can see the quantity in the tank by means of a coloured ball inside the level tube in the rear right-hand part of the machine.

i **N.B.:** the solution tank can also be filled by inserting a water hose in the hole in the cap.

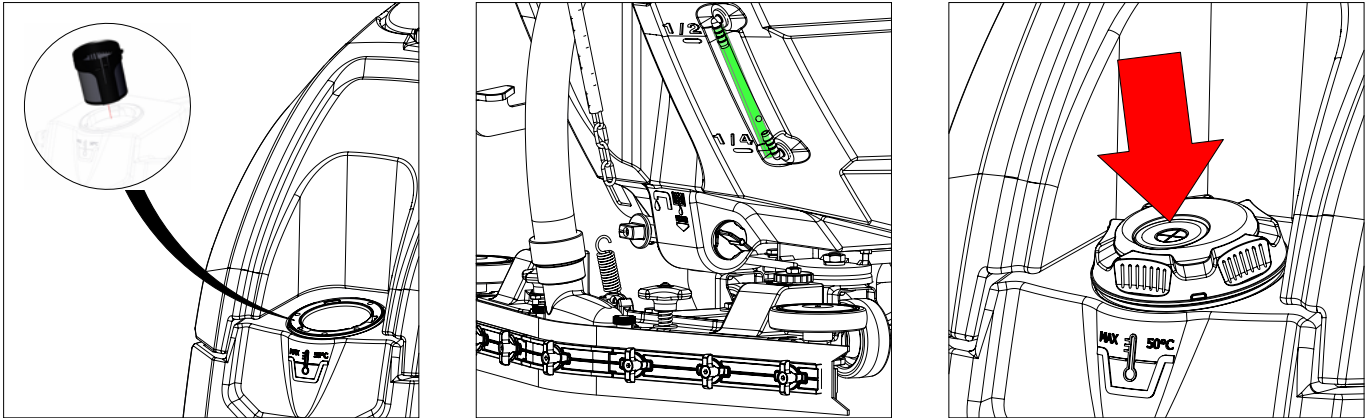

! **ATTENTION:** fill with clean water, at a temperature no higher than 50°C (122°F) and no lower than 10°C (50°F).

! **ATTENTION:** Add the liquid detergent to the tank in the concentration and manner indicated on the detergent manufacturer's label.

i **N.B.:** the cap can be used to measure the detergent; it can hold 100ml or 0.026 gal of liquid detergent.

i **N.B.:** to prevent an excessive amount of foam from forming, which could damage the suction motor, use the minimum percentage of detergent required.

! **CAUTION:** protective gloves should always be worn when handling detergents or acidic or alkaline solutions, to avoid serious hand injuries.

! **ATTENTION:** always use detergents which have a manufacturer's label that indicates that they are suitable for use with floor scrubbing machines. Do not use acid or alkaline products or solvents without this indication.

! **ATTENTION:** in order to avoid damaging the machine's water system, acidic or alkaline maintenance detergents can be used, as long as they have pH values between 4 and 10, and do not contain: oxidising agents, chlorine or bromine, formaldehyde, mineral solvents.

! **ATTENTION:** Always use low-foam detergent. To avoid the production of foam, put a minimum quantity of antifoam liquid in the recovery tank before starting to clean. Do not use pure acids.

ASSEMBLY OF BRUSHES OR DRIVE DISCS

To mount the brush or pad holder in the brush head, follow the steps below:

1. Take the machine to the maintenance area.

! **WARNING:** the place designated for this operation must comply with current regulations concerning safety at work and current environmental protection regulations.

2. Carry out all the operations required to put the machine in a safe condition. See the "MACHINE SAFETY" paragraph.

! **CAUTION:** it is recommended to wear the appropriate PPE (Personal Protective Equipment), suitable for the work to be carried out.

3. Go to the front of the machine.
4. Insert the brush in the brush-holder plate.
5. Rotate the brush clockwise until its three buttons slot into the notches in the brush-holder plate.
6. Turn the brush clockwise in steps, pushing the button towards the coupling spring until it is locked in place.

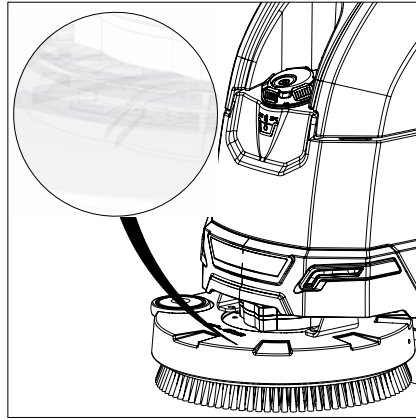
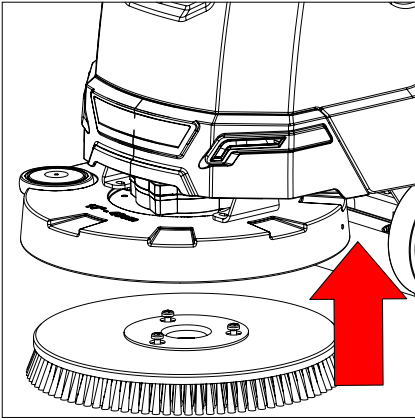

ASSEMBLING THE ABRASIVE PAD

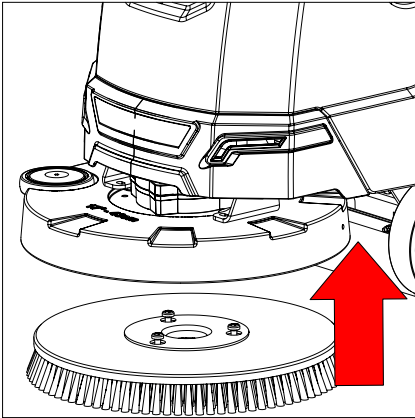

To mount the abrasive pad in the drive disc in the brush head, perform the following.:

1. Take the machine to the maintenance area.



WARNING: the place designated for this operation must comply with current regulations concerning safety at work and current environmental protection regulations.

2. Carry out all the operations required to put the machine in a safe condition. See the “MACHINE SAFETY” paragraph.



CAUTION: it is recommended to wear the appropriate PPE (Personal Protective Equipment), suitable for the work to be carried out.

3. Go to the front of the machine.
4. Remove the male centre lock insert from the pad holder.
5. Insert the abrasive pad into the abrasive part present in the center lock.
6. Reassemble the male centre lock insert in the pad holder.

ASSEMBLING THE SQUEEGEE BODY

For packaging reasons, the squeegee body comes disassembled from the machine. In order to mount it on the squeegee support, do the following:

1. Take the machine to the maintenance area.



WARNING: the place designated for this operation must comply with current regulations concerning safety at work and current environmental protection regulations.

2. Carry out all the operations required to put the machine in a safe condition. See the “MACHINE SAFETY” paragraph.



CAUTION: it is recommended to wear the appropriate PPE (Personal Protective Equipment), suitable for the work to be carried out.

3. Stand at the back of the machine.
4. Loosen the knobs on the squeegee body pre-assembly.
5. First of all insert the left pin on the squeegee body in the left slot on the squeegee support, making sure the washer rests in the upper part of the squeegee body.
6. Insert the vacuum tube in the sleeve on the squeegee body.

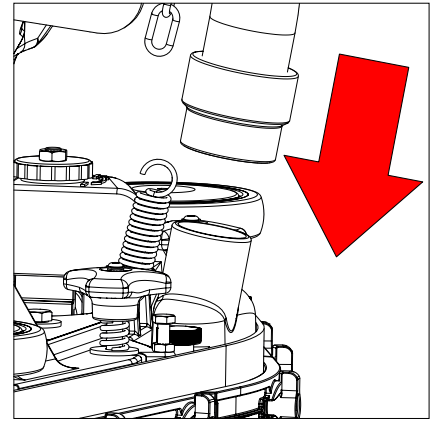
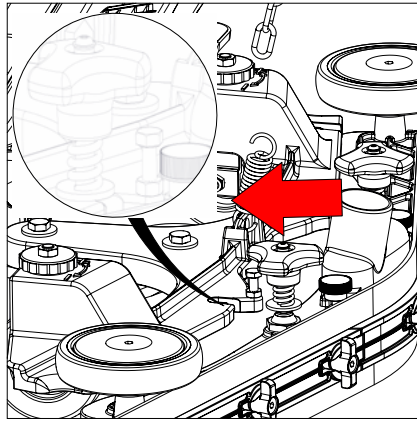
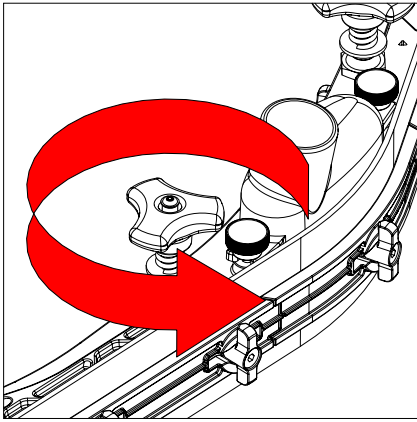

⚠ ATTENTION: the squeegee comes pre-adjusted but, if necessary, read the “ADJUSTING THE SQUEEGEE RUBBER BLADES” paragraph.

ASSEMBLING THE SPLASH GUARD BRUSH HEAD

For packaging reasons, the brush head splash guard comes disassembled from the machine. To assemble on the brush head body, proceed as follows:

1. Take the machine to the maintenance area.

⚠ WARNING: the place designated for this operation must comply with current regulations concerning safety at work and current environmental protection regulations.

2. Carry out all the operations required to put the machine in a safe condition. See the “MACHINE SAFETY” paragraph.

🧤 CAUTION: it is recommended to wear the appropriate PPE (Personal Protective Equipment), suitable for the work to be carried out.

3. Go to the front of the machine.
4. Place the splashguard in contact with the brush head body.
5. Place the blade inside the slot on the splashguard.
6. Hook the blade to the brush head body, using the spring hook to facilitate the operation.

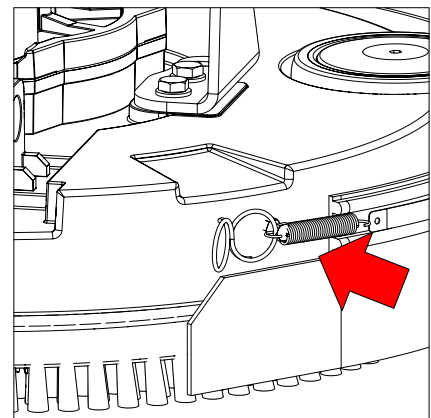
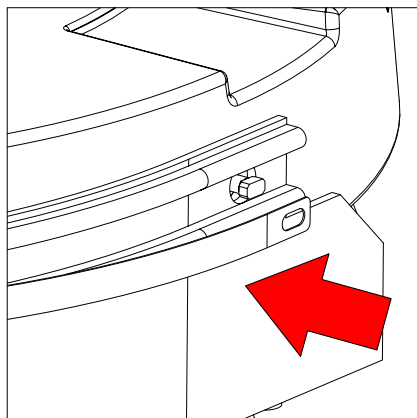
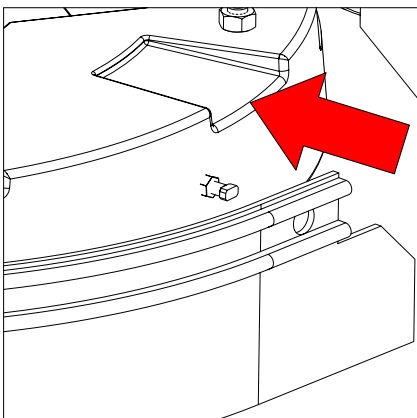

WORK PREPARATION CHECKLIST

CHECK	SOLUTION
Check for any fluid leaks	Contact your service centre of reference, or the one closest to you.
Check the tyres to make sure they are not damaged	Contact your service centre of reference, or the one closest to you.
Check the charge level of the battery box	Check the charge level of the battery box on the control display, and recharge if necessary. See the "RECHARGING THE BATTERIES (BATTERY-POWERED VERSIONS)" paragraph.
Check if the solution tank is full	If the solution tank is empty, fill it. See the "FILLING THE SOLUTION TANK" paragraph.
Check if the recovery tank is full	If the recovery tank is full, empty it. See the "DRAINING THE RECOVERY TANK" paragraph.
Check the condition of the collection filter tray on the recovery tank	If the tray is dirty, clean it. See the "CLEANING THE RECOVERY TANK TRAY" paragraph.
Check the condition of the water system filter	If the cartridge in the filter body is dirty, clean it. See the "CLEANING THE SOLUTION TANK CAP-FILTER" paragraph.
Check the condition of the brushes in the discoid scrubbing brush head	If the brush in the brush head is dirty, clean it. See the "CLEANING THE BRUSH - PAD HOLDER" paragraph.
	If the brush in the brush head is worn or damaged, replace it. See the "REPLACING THE BRUSHES OR PAD HOLDERS" paragraph.
Check the condition of the squeegee	If the squeegee is dirty, clean it. See the "CLEANING THE SQUEEGEE" paragraph.
Check the state of wear of the rubber blades in the squeegee	If the state of wear of the squeegee rubber blades is unsuitable for the job to be carried out, replace them. See the "REPLACING THE SQUEEGEE RUBBER BLADES" paragraph.
Check the condition of the squeegee vacuum tube.	If the squeegee vacuum hose is dirty, clean it. See the "CLEANING THE SQUEEGEE VACUUM HOSE" paragraph.
Check that the gasket on the recovery tank cover is not damaged or worn	Contact your service centre of reference, or the one closest to you.

WORKING PROGRAMS

The PRO version machine can be used with the following working programs:

1. **ECO MODE:** for light maintenance cleaning tasks, using fewer resources and operating at a low noise level. See the "ECO MODE WORKING PROGRAM" paragraph.
2. **MANUAL MODE:** the operator freely evaluates and chooses the parameters based on the cleaning requirements that arise during the job. See the "MANUAL MODE WORKING PROGRAM" paragraph.

ECO MODE WORKING PROGRAM

The ECO MODE working program can be used for light maintenance work.

The ECO MODE program is a program which guarantees the best possible performance in terms of consumption and cleaning.

- i** **N.B.:** when the machine is switched on, the function board will automatically activate the ECO MODE working program.

The ECO MODE working program can be enabled:

1. With the machine in scrubbing mode, press the  button on the control panel.

- i** **N.B.:** the word "ECO" will appear on the control display as soon as the button is pressed.



- i** **N.B.:** to deactivate the ECO MODE working program, simply:

- alter the amount of detergent solution in the machine's water system (see "ADJUSTING THE DETERGENT SOLUTION FLOW")
- (for PRO versions) alter the pressure exerted on the brush head (see "ADJUSTING THE PRESSURE EXERTED ON THE BRUSH HEAD (PRO VERSION)")
- activate the maximum vacuum function (see "NOISELESS SUCTION")

- i** **N.B.:** when the ECO MODE program is not active, the word ECO will not be shown on the control display.

- i** **N.B.:** by selecting the ECO MODE working program, the values of the working parameters (detergent solution flow and brush head pressure) will be automatically changed.

The pre-set parameters are those shown below:

Detergent Solution	Brush head pressure	Maximum vacuum
Minimum	Minimum	Deactivated

MANUAL MODE WORKING PROGRAM

With the MANUAL MODE working program, it is the operator who evaluates and chooses the parameters based on the cleaning requirements that arise during the course of the work activities.

To deactivate the ECO MODE working program, simply:

- alter the amount of detergent solution in the machine's water system (see "ADJUSTING THE DETERGENT SOLUTION FLOW")
- (for PRO versions) alter the pressure exerted on the brush head (see "ADJUSTING THE PRESSURE EXERTED ON THE BRUSH HEAD (PRO VERSION)")
- activate the maximum vacuum function (see "NOISELESS SUCTION")

WORKING MODE

TRANSFER WORKING MODE

In the TRANSFER working mode, both the brush head and the squeegee are in their maintenance position. This working mode is used to transfer the machine from one work site to another, or from the work site to the maintenance site.

To use the basic versions of the machine in transfer mode, proceed as follows:

1. Stand at the back of the machine.
2. Bring the brush head to the maintenance position (raised off the floor), pressing the brush head control pedal all the way down and then shifting it to the right before releasing it so it cannot be moved.
3. Bring the squeegee to the maintenance position (raised off the floor) by rotating the lever at the back of the machine upwards.

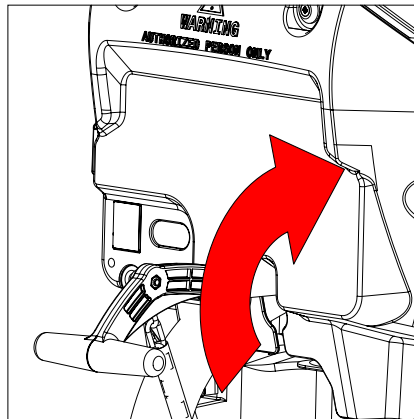
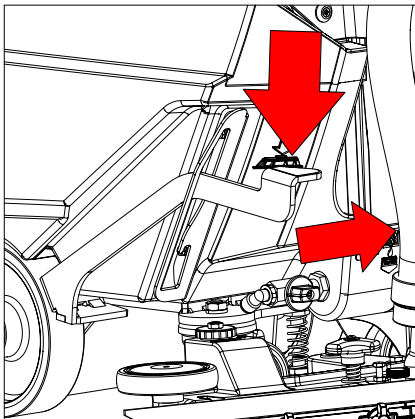

To use the pro versions of the machine in transfer mode, proceed as follows:

1. Stand at the back of the machine.
2. With the machine switched on, bring the brush head to the maintenance position (raised off the floor) by pressing the brush head control button  on the control panel.

i N.B.: when the brush head is in the maintenance position, the LED in the button is OFF.

3. Bring the squeegee to the maintenance position (raised off the floor) by rotating the lever at the back of the machine upwards.

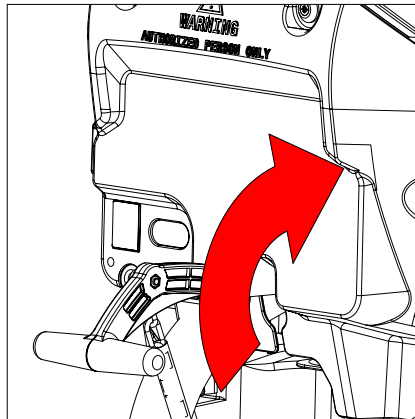
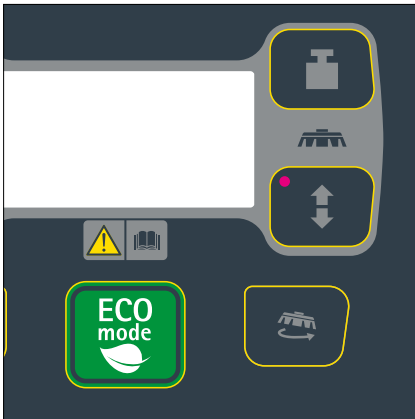

SCRUBBER WORKING MODE

In the SCRUBBING MACHINE working mode, the brush head and squeegee are in their working positions. This working mode is used to scrub and dry the floor at the same time.

To use the basic versions of the machine in scrubbing mode, proceed as follows:

1. Stand at the back of the machine.
2. Bring the brush head to the working position (in contact with the floor), pressing the brush head control pedal all the way down and then shifting it to the left before releasing it so it can be moved.
3. Bring the squeegee to the working position (in contact with the floor) by rotating the lever at the back of the machine downwards.

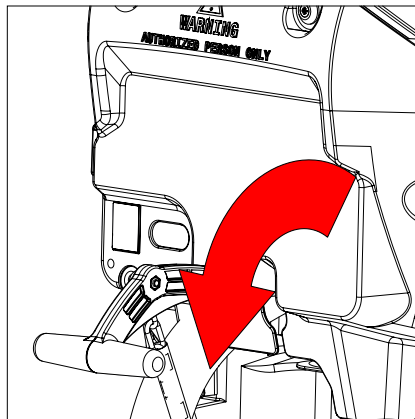
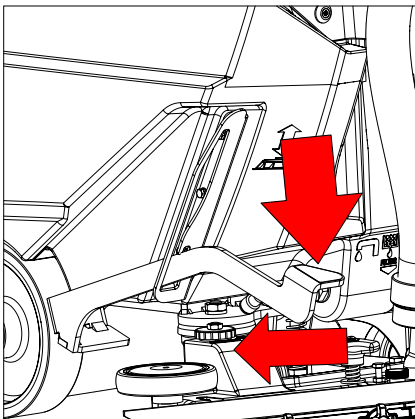

To use the pro versions of the machine in scrubbing mode, proceed as follows:

1. Stand at the back of the machine.
2. With the machine switched on, bring the brush head to the working position (in contact with the floor) by pressing the brush head control button  on the control panel.

i N.B.: when the brush head is in the working position, the LED in the button is ON.

3. Bring the squeegee to the working position (in contact with the floor) by rotating the lever at the back of the machine downwards.

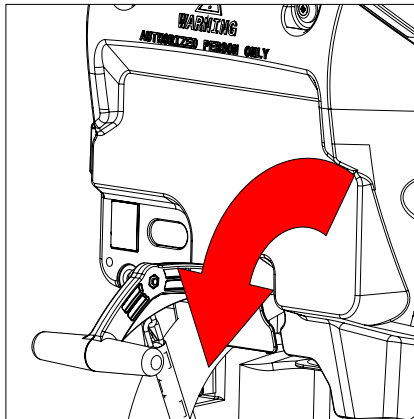
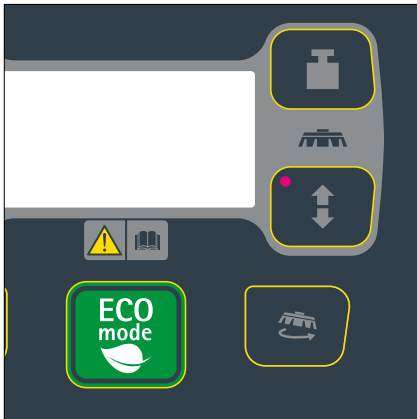

PRE-SCRUB WORKING MODE

In the PRE-SCRUBBING working mode, only the brush head is in the working position, with the squeegee remaining in its maintenance position. This working mode is used to thoroughly scrub the floor without needing to dry it.

To use the basic versions of the machine in pre-scrubbing mode, proceed as follows:

1. Stand at the back of the machine.
2. Bring the brush head to the working position (in contact with the floor), pressing the brush head control pedal all the way down and then shifting it to the left before releasing it so it can be moved.
3. Bring the squeegee to the maintenance position (raised off the floor) by rotating the lever at the back of the machine upwards.

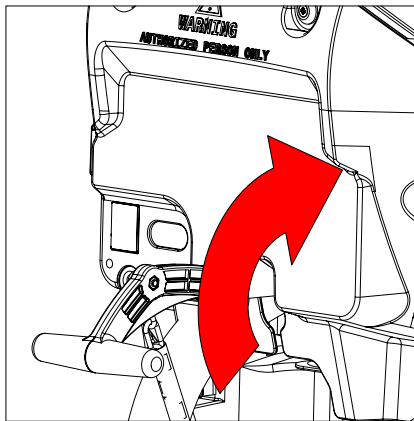
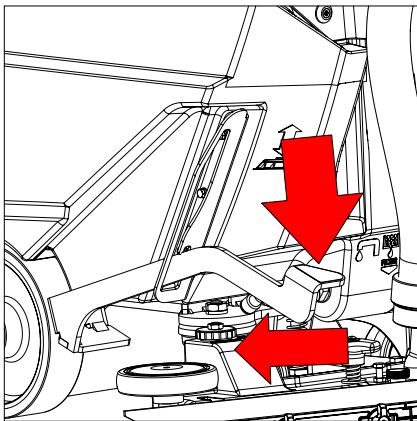

To use the pro versions of the machine in pre-scrubbing mode, proceed as follows:

1. Stand at the back of the machine.
2. Bring the brush head to the working position (in contact with the floor) by pressing the brush head control button  on the control panel.

i N.B.: when the brush head is in the working position, the LED in the button is ON.

3. Bring the squeegee to the maintenance position (raised off the floor) by rotating the lever at the back of the machine upwards.

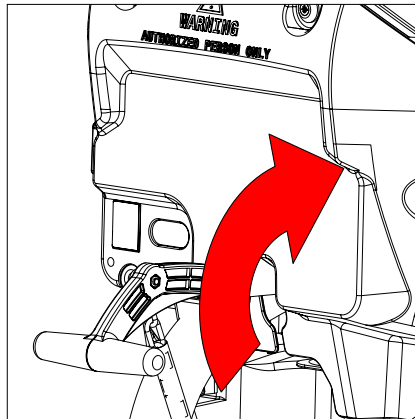

DRYING WORKING MODE

In the DRYING working mode, only the squeegee is in the working position, with the brush head remaining in its maintenance position. This working mode is used to dry the floor after a pre-scrubbing phase.



ATTENTION: The drying without scrubbing operation (drying) should only be carried out if the machine was used beforehand to carry out a scrubbing without drying operation (pre-scrub).

To use the basic versions of the machine in drying mode, proceed as follows:

1. Stand at the back of the machine.
2. Bring the brush head to the maintenance position (raised off the floor), pressing the brush head control pedal all the way down and then shifting it to the right before releasing it so it cannot be moved.
3. Bring the squeegee to the working position (in contact with the floor) by rotating the lever at the back of the machine downwards.

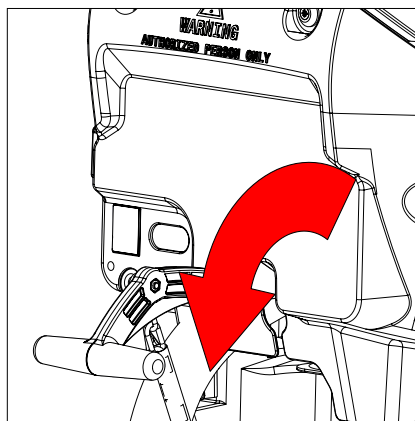
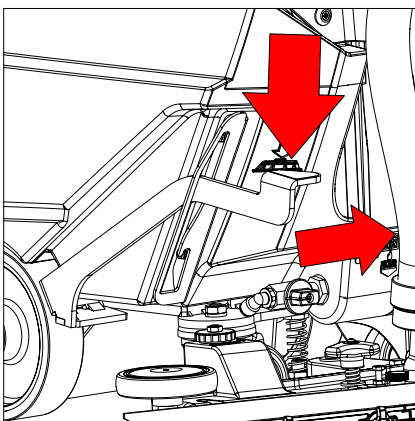

To use the pro versions of the machine in drying mode, proceed as follows:

1. Stand at the back of the machine.
2. Bring the brush head to the maintenance position (raised off the floor) by pressing the brush head control button  on the control panel.



N.B.: when the brush head is in the maintenance position, the LED in the button is OFF.

- Bring the squeegee to the working position (in contact with the floor) by rotating the lever at the back of the machine downwards.

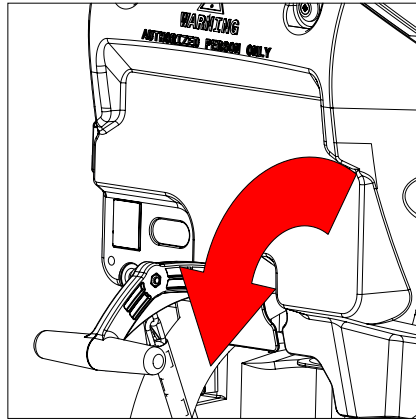

STARTING WORK

- Carry out all the checks in the “WORK PREPARATION CHECKLIST” chapter.
- Carry out all the operations required to put the machine in a safe condition. See the “MACHINE SAFETY” paragraph.
- Go to the front left-hand side of the machine.
- Grip the handle and turn the recovery tank to its maintenance position.

⚠ ATTENTION: to prevent the recovery tank from rotating accidentally, turn it until the retainer cable is fully tensioned.

⚠ ATTENTION: the following operations must be carried out by qualified personnel. Incorrect operations could result in machine malfunctions.

- Check the connector on the machine's electrical system wiring is connected to the connector on the power cable from the battery box. If it isn't, connect it.
- Grip the handle and turn the recovery tank to its working position.
- Insert the key into the slot on the right side of the control handlebar.
- Switch on the machine, making a quarter turn clockwise with the key (1).

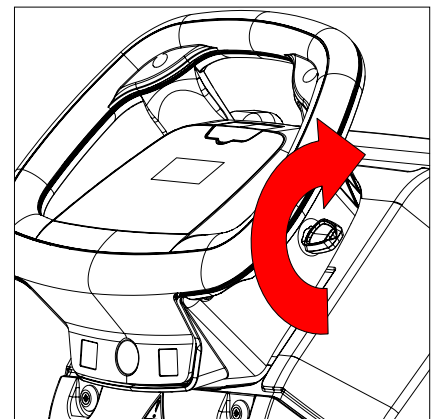
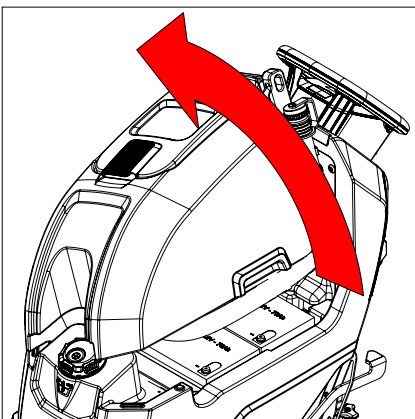

- At switch-on, the control display visualises a series of pages; the third one shows the machine programming characteristics.

i **N.B.:** the type of battery programmed for the battery control board is shown at the top of the screen. The total hour meter and partial hour meter of the machine are shown in the middle of the screen, on the upper and lower rows respectively. The software version of the function board (SwF) and the software version of the display (SwD) are shown at the bottom of the screen, on the left- and right-hand sides respectively.

i **N.B.:** the machine is set so the ECO MODE working program is active at switch on, with the brush head gearmotor deactivated.

9. Bring the brush head to its working position (in contact with the floor). For basic versions, press the brush head control pedal all the way down and then shift it to the left before releasing it so it can rotate. For pro versions, press the brush head control button  on the control panel.

i **N.B.:** when the brush head is in the working position, the LED in the button is ON.

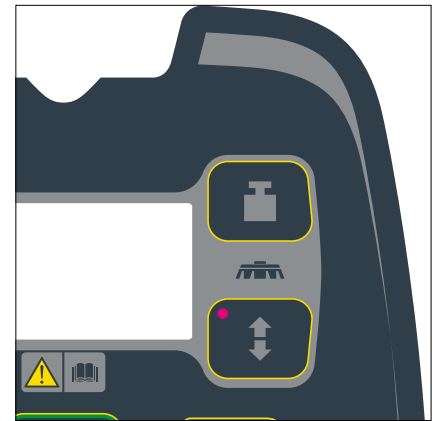
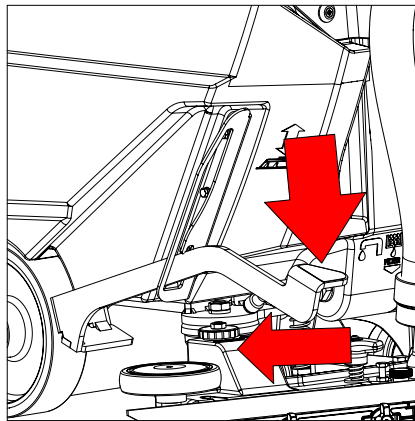
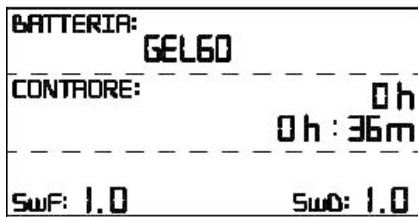

10. Bring the squeegee to the working position (in contact with the floor) by rotating the lever at the back of the machine downwards.







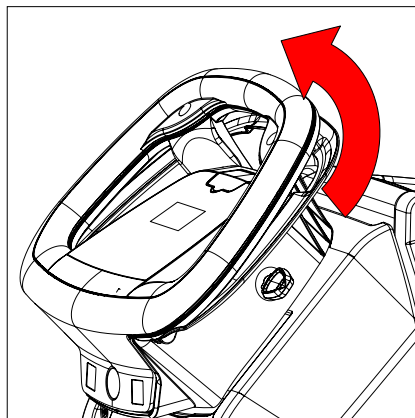
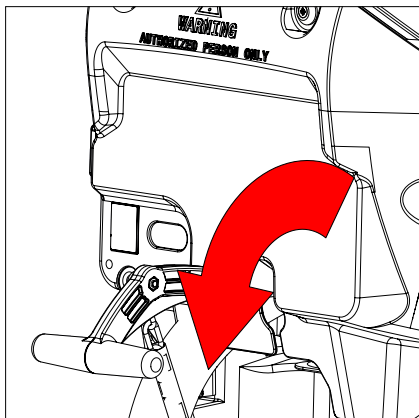





11. For pro versions, press the "dead man's" lever to activate the brush head control actuator.

i **N.B.:** the brush motor; the solenoid valve, and the detergent solution pump only begin functioning once the brush head is in its working position.

i **N.B.:** the suction motor is only started up when the squeegee is in the working position.



12. The machine will now begin operating at maximum efficiency until the detergent solution is finished or the battery box runs flat.

-  **N.B.:** during the first few metres of work, make sure the amount of solution is sufficient to wet the floor. If it isn't, adjust the detergent solution flow - see "REGULATING THE FLOW OF DETERGENT SOLUTION".
-  **N.B.:** during the first few metres of work, make sure the squeegee dries the floor properly. If it doesn't, adjust it - see "SQUEEGEE RUBBER BLADES ADJUSTMENT".
-  **N.B.:** pick up any large pieces of waste before performing the cleaning operations; pick up wire, tape, string, large pieces of wood, or any other types of refuse that could wrap around the brushes or become entangled.
-  **N.B.:** drive the machine along the most linear path possible. Avoid hitting any obstacles and scratching the sides of the machine. Overlap the working widths by several centimetres.
-  **N.B.:** avoid turning the steering wheel too sharply while the machine is in motion. The machine reacts quickly to the steering wheel's movements.
-  **N.B.:** adjust the machine speed, the brush pressure and the flow of the solution based on the type of cleaning to be carried out.
-  **N.B.:** drive the machine slowly on tilting surfaces and on downhill slopes. Wash by moving the machine uphill rather than downhill.
-  **ATTENTION:** slow down on ramps and slippery surfaces.
-  **ATTENTION:** do not use the machine in areas where the ambient temperature is higher than 43°C (110°F). Do not use the scrubbing functions in areas where the ambient temperature is less than freezing 0°C (32°F).
-  **ATTENTION:** in transfer mode, the machine can only drive on ramps not exceeding 2%; while in scrubbing machine working mode (with GVW weight), it can work on slopes not exceeding 2%.
-  **N.B.:** The machine is not equipped with an overflow device, because the volume of the recovery tank is greater than the capacity of the solution tank. In extraordinary cases, there is a mechanical device (float) under the recovery tank lid that, when the recovery tank is full, shuts off the air to the vacuum motor intake to protect it; the sound of the suction motor will then be deeper. Empty the recovery tank - see "EMPTYING THE RECOVERY TANK".
-  **N.B.:** if the detergent solution in the tank runs out during the work, top it up - see "FILLING THE SOLUTION TANK".

ADDITIONAL FUNCTIONS

HOUR METER

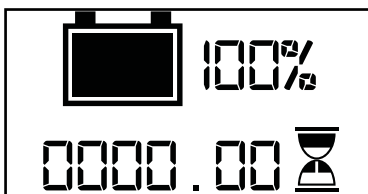

On the control panel of the machine, there is a control display; the hour meter is shown on the lower row in the middle. The hour meter allows the user to view the machine's total time of use via a series of numbers.

-  **N.B.:** the digits preceding the (".") identify the hours, while the digits that come after the "." identify the tenths of an hour, a tenth of an hour corresponds to six minutes.

BATTERY LEVEL INDICATOR

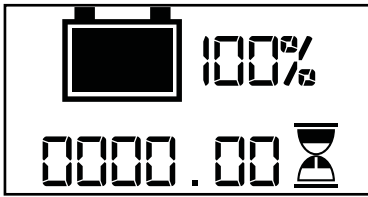

On the control panel of the machine, there is a control display; the battery box charge percentage is shown on the upper row in the middle.

The battery box charge percentage indicator consists of two charge level symbols, the first being a graphic symbol and the second a number indicating the charge percentage.

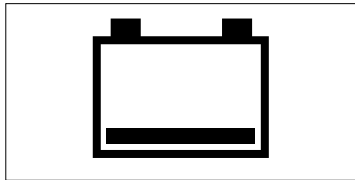

i **N.B.:** the control display shows the batteries' charge percentage with respect to their maximum capacity, and the function board transforms the batteries' voltage value into a percentage value.

i **N.B.:** the graphic symbol consists of five charge levels, each representing approximately 20% of the residual charge.

i **N.B.:** with a residual charge of 20% or less, the graphic symbol starts to flash and after a few seconds it will appear larger in the middle of the screen. If this happens, take the machine to the designated battery box charging point.

flash and after a few seconds machine to the designated

i **N.B.:** a few seconds after the battery box charge level reaches 20%, the brush motor switches off automatically. The remaining charge is sufficient for completing the drying task before recharging the battery box.

i **N.B.:** a few seconds after the battery charge level reaches 10%, the suction motor switches off automatically. With the remaining charge, it is still possible, however, to move the machine to the designated battery box recharging station.

ADJUSTMENT OF THE DETERGENT SOLUTION FLOW

To adjust the flow of detergent solution during work, proceed as follows:



1. During the first few working meters check that the amount of solution is sufficient to wet the floor, but not excessive to exit the splash guard.

2. To adjust the detergent solution flow, use the "+" and "-" buttons on the control panel.

i **N.B.:** the flow of detergent solution on the brush can be adjusted to one of three levels, from 0 to 2. The adjustment is shown with the symbol on the left on the control display (in the picture here, the level is shown as 0).

i **N.B.:** each press of the button cyclically increases the level of detergent solution in the machine's water system.

i **N.B.:** If the flow is set to 0, there is no emission of detergent solution.

i **N.B.:** to change the values relating to the amount of detergent solution in the machine's water system, contact your service centre of reference or the one closest to you.



NOISELESS SUCTION



This machine can reduce the noise level generated by the vacuum process during the work cycle. To do this:

While working in SCRUBBING or VACUUM mode (i.e. with the squeegee in contact with the floor), press the  button on the control panel for at least three seconds.

- i** **N.B.:** as soon as the noiseless suction function is activated, the relative LED on the control panel will turn off.
- i** **N.B.:** to deactivate the noiseless suction function, press the button on the control panel again for at least three seconds.

i **N.B.:** as soon as the noiseless suction function is deactivated, the relative LED on the control panel will turn on.

EXTRA PRESSURE FUNCTION (PRO VERSIONS)



This machine can increase the pressure exerted on the brush during the work cycle. To do this:

While working in PRE-SCRUBBING or SCRUBBING mode (i.e. with the brush head in contact with the floor), press the  button on the control panel.

- i** **N.B.:** the pressure exerted on the brush head can be adjusted at two levels (minimum and maximum). The adjustment is shown with the symbol on the right on the control display (in the picture here, the level is shown as "maximum").
- i** **N.B.:** each press of the button cyclically increases the level of detergent solution in the machine's water system.



BRUSH UNCOUPLING FUNCTION



The machine is equipped with a button that activates the brush uncoupling function, when it is necessary to carry out maintenance or replace the brushes in the brush head. To activate the function, proceed as follows:

1. With the brush head in the maintenance position (raised off the floor), press the  button on the control panel.
2. The machine will automatically perform the BRUSH UNCOUPLING function.

i **N.B.:** once the maintenance position sequence has been activated, it is not possible to activate other functions or move the machine.

! **CAUTION:** make sure that no people or objects are in the machine's vicinity during this operation.

i **N.B.:** during the brush uncoupling operation, the control display will show the  symbol flashing (full screen).

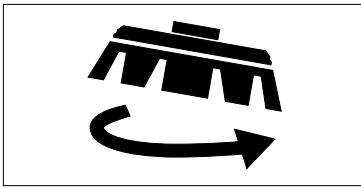

REVERSE GEAR

To reverse, proceed as follows:

1. Stop the machine.
2. Bring the brush head to its maintenance position (raised off the floor). For basic versions, press the brush head control pedal all the way down and then shift it to the right before releasing it so it cannot move. For pro versions, press the brush head control button  on the control panel.

i **N.B.:** when the brush head is in the maintenance position, the LED in the button is OFF.

3. Bring the squeegee to the maintenance position (raised off the floor) by rotating the lever at the back of the machine upwards.
4. Move the machine in reverse.

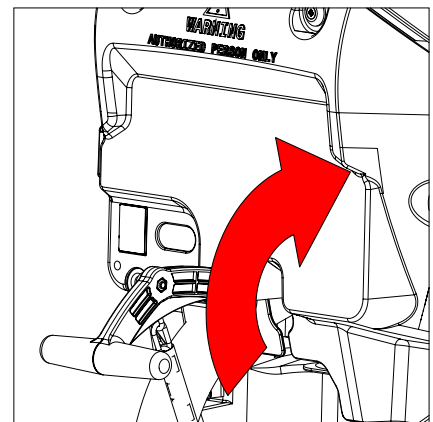
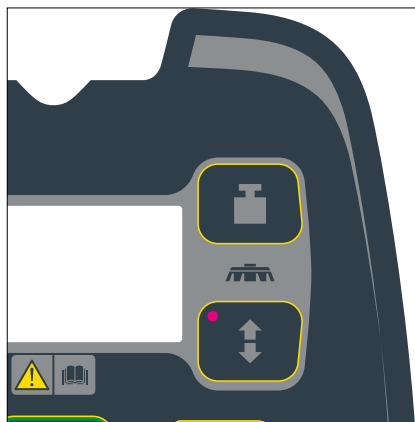
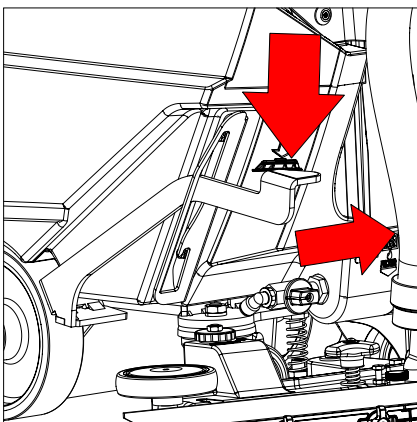

ALARM SCREEN



If an error occurs, the control display will show the corresponding alarm screen, which will remain visible until the error has been resolved. It shows:

- the alarm number
- a brief description

When an error occurs, do as follows:

1. Stop the machine immediately.
2. Turn the machine off by turning the main switch to "0", making a quarter turn anti-clockwise with the key.
3. Wait at least ten seconds then turn the machine back on by bringing the main switch to "I", making a quarter turn clockwise with the key.
4. If the error persists, contact your service centre of reference or the one closest to you.

 **N.B.:** the error screen will remain visible until the error has been resolved.

OPTIONAL FUNCTIONS

FRONT HEADLIGHTS

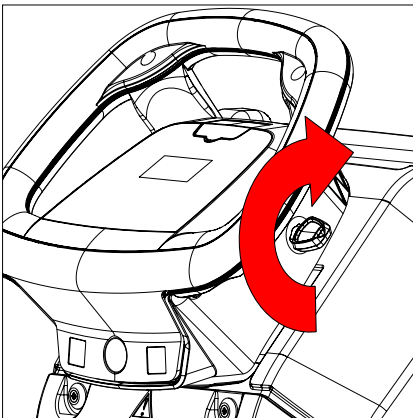



Upon request, the machine can be equipped with headlights which are activated when the machine is turned on via the key switch.

AT THE END OF THE WORK

At the end of the work, and before carrying out any type of maintenance, perform the following operations:

1. Make sure the machine is in a safe condition - see "MACHINE SAFETY".
2. Take the appliance to the dedicated dirty water drainage area.

 **WARNING:** the place designated for this operation must comply with current regulations concerning safety at work and current environmental protection regulations.

 **CAUTION:** it is recommended to wear the appropriate PPE (Personal Protective Equipment), suitable for the work to be carried out.

3. Carry out all the daily maintenance procedures on the machine - see "MAINTENANCE PROGRAM".
4. Once the daily maintenance operations are complete, take the machine to the designated storage location.

ATTENTION: Park the machine in an enclosed place, on a flat surface; near the machine there must be no objects that could either damage it, or be damaged through contact with it.

ATTENTION: before parking the machine, read the SHUTTING THE MACHINE DOWN paragraph in the GENERAL SAFETY REGULATIONS document supplied with the machine.

5. Make sure the machine is in a safe condition - see "MACHINE SAFETY".

MAINTENANCE PLAN

The importance of machine maintenance should not be underestimated.

By ensuring the machine is inspected regularly, we can replace all parts that become worn in a timely manner. In addition, we can also recognise faults quickly, thus increasing the useful life of our machine.

i **N.B.:** through its network of certified service centres, the manufacturer provides special offers on maintenance service coupons, such as those made available in automotive workshops. See

<https://www.fimap.com/it/fimap/22/manutenzione-e-riparazione.html>

First, it is important to understand the difference between the various types of maintenance:

- routine maintenance is an activity designed to keep the machine in good working order.
- extraordinary maintenance regards work carried out to implement substantial updates on the machine.

i **N.B.:** the primary purpose of routine maintenance is to maintain the performance of the machine's various functions, checking for any worn or faulty elements. A fault that is not fixed or an excessively worn part could cause damage to the machine or injure persons in the vicinity.

i **N.B.:** The main purpose of extraordinary maintenance is to replace any worn or defective elements.

i **N.B.:** In addition, maintenance enables the operator to use the machine in a safer manner, in the knowledge that the risk of unforeseen events has been reduced as far as possible.

i **N.B.:** The use and maintenance manual contains all the procedures to be carried out during routine maintenance of the machine. By following these instructions, even individuals with no particular expertise in this area can check the machine and replace any parts necessary, taking a DIY approach. However, it is essential to remember the importance of entrusting the work to genuine professionals. An experienced specialist may notice details that could escape the notice of a less observant and expert eye.

i **N.B.:** A dilemma may arise during maintenance: which spare parts are best? The manufacturer supplies original spare parts identical to the parts that need replacing. These are the best choice because they are durable and long-lasting, and maintain unaltered machine performance.

i **N.B.:** the manufacturer's service centres use these spare parts, but in the case of an unauthorised workshop we recommend explicitly asking the technicians to use only these products. Using official spare parts extends the longevity of your machine.

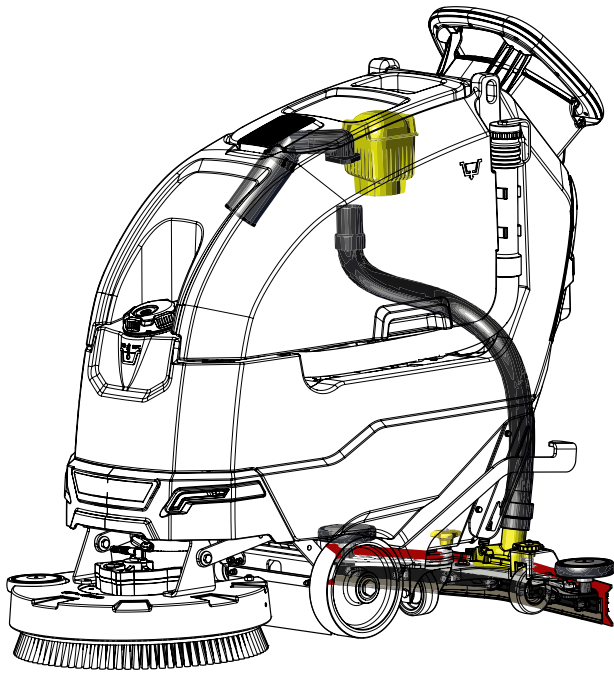

1 - SUCTION SYSTEM

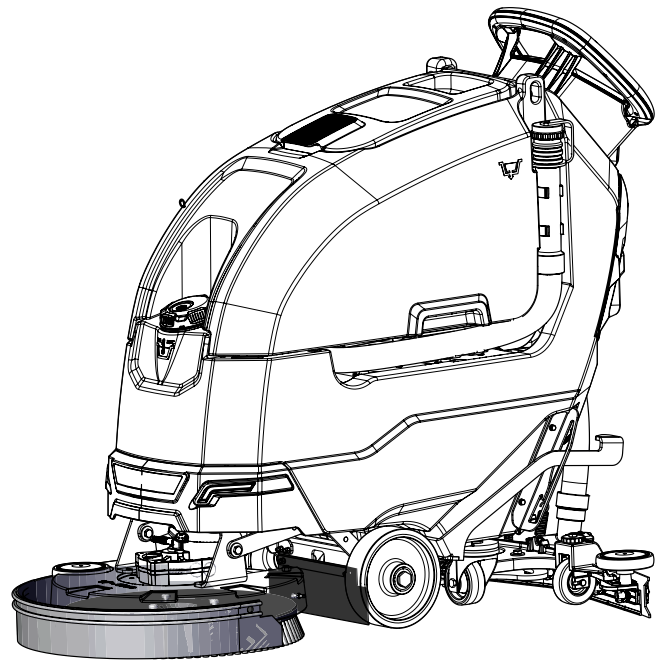

2 - SCRUBBING SYSTEM

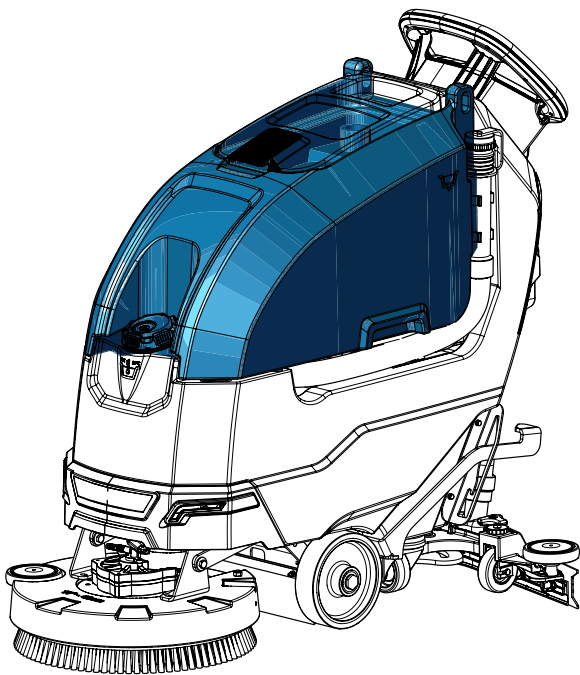

3 - RECOVERY TANK



4 - SOLUTION TANK

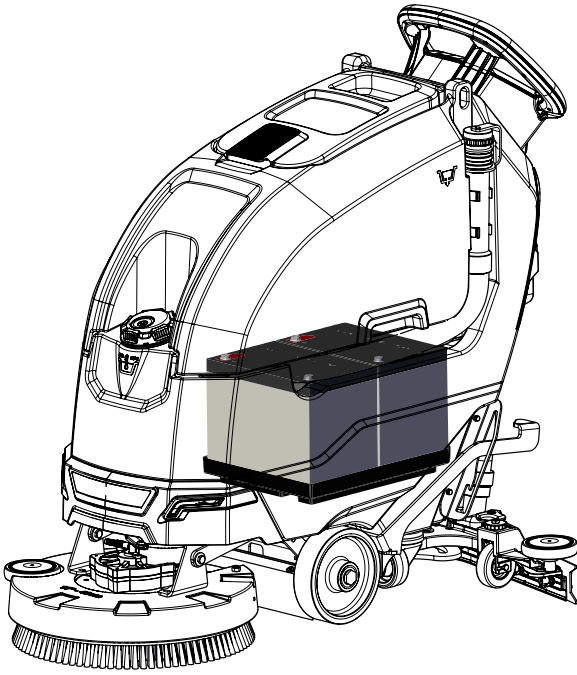

5 - BATTER- POWERED SYSTEM



6 - ON-BOARD BATTERY CHARGER

ROUTINE MAINTENANCE INTERVAL TABLE (NORMAL WORKER)

- i** **N.B.:** "general worker" means someone able to handle tasks for which physical effort is required to carry out specific but simple job-related procedures, or responsible for tasks or services calling for aptitude or for knowledge that can be acquired in a few days.
- i** **N.B.:** "specialised operator" means someone able to handle specific tasks requiring special practical skills obtained via technical-practical preparation organised by technicians from the manufacturer's service centre.

DAILY MAINTENANCE











Reference	Description	Procedure	Paragraph
1	Clean squeegee rubber blades	Clean the inner and outer surface of the rubber blades present in the squeegee of the machine	Read the "CLEANING THE SQUEEGEE" paragraph
	Clean squeegee suction chamber	Clean the inner surface of the suction chamber present in the squeegee body of the machine	
	Clean the squeegee nozzle	Clean the inner surface of the suction nozzle present in the squeegee body of the machine	
	Clean the squeegee suction hose	Clean the inside of the suction hose that connects the squeegee to the recovery tank	Read the "CLEANING THE SQUEEGEE VACUUM TUBE" paragraph
	Clean the waste collection tray present in the recovery tank	Clean the waste tray of any dirt or fouling, the tray is inside the recovery tank	Read the "CLEANING THE RECOVERY TANK DRIP TRAY" paragraph
	Clean the suction motor inlet air filter	Clean the inlet air filter of any impurities or fouling, the filter is located inside the recovery tank	Read the "CLEANING THE SUCTION MOTOR INTAKE AIR FILTER" paragraph
2	Cleaning the brush	Remove impurities and waste from the bristles, clean the bristles under a jet of water	Read the "CLEANING THE BRUSH - PAD HOLDER" paragraph
	Cleaning the splash guard rubber blade	Clean the inner and outer surface of the splash guard rubber blade	Read the "CLEANING THE BRUSH HEAD SPLASHGUARD" paragraph
3	Empty the recovery tank	Using the drain hose, empty the recovery tank	Read the "EMPTYING THE RECOVERY TANK" paragraph
4	Clean the solution tank filter - cap	Clean the water system filter of any dirt or fouling, the cap - filter located at the rear of the machine	Read the "CLEANING THE SOLUTION TANK CAP - FILTER" paragraph

MAINTENANCE AFTER 50 WORKING HOURS

Reference	Description	Procedure	Paragraph
1	Clean the guard of the suction motor inlet air filter	Clean the guard of the suction motor inlet air filter present inside the recovery tank	Read the "CLEANING THE SUCTION MOTOR INTAKE AIR FILTER" paragraph
3	Clean the recovery tank	Empty and clean the inside of the recovery tank	Read the "EMPTYING THE RECOVERY TANK" paragraph
4	Clean the solution tank	Empty and clean the inside of the solution tank	Read the "EMPTYING THE SOLUTION TANK" paragraph

ROUTINE MAINTENANCE INTERVAL TABLE (SPECIALIST WORKER)

MAINTENANCE AFTER 50 WORKING HOURS

Ref.	Description	Notes
1	Check the state of wear of the rubber blades in the squeegee	 ATTENTION: if the state of wear of the rubber blades does not allow for proper drying, contact your service centre of reference or the one closest to you to have them replaced
	Check the integrity of the suction nozzle present in the squeegee	 ATTENTION: if the suction nozzle is damaged and does not ensure proper suction of the detergent solution, contact your service centre of reference or the one closest to you to have it replaced
	Check the integrity of the squeegee suction hose	 ATTENTION: if the squeegee vacuum hose is damaged and does not ensure proper suction of the detergent solution, contact your service centre of reference or the one closest to you to have it replaced
	Check the integrity of the waste tray present in the recovery tank	 ATTENTION: if the waste tray in the recovery tank is damaged and does not ensure efficient solution filtration, contact your service centre of reference or the one closest to you to have it replaced
	Check the integrity of the suction motor inlet air filter	 ATTENTION: if the air filter on the suction motor inlet is damaged and does not hold back the solution efficiently, contact your service centre of reference or the one closest to you to have it replaced
	Check the integrity of the guard at the suction motor inlet air filter	 ATTENTION: if the guard on the suction motor inlet air filter is damaged and does not hold back the solution efficiently, contact your service centre of reference or the one closest to you to have it replaced
2	Check the state of wear of the bristles in the brush	 WARNING: if the height of the bristles in the brush does not allow for the proper scrubbing of the floor, contact your service centre of reference or the one closest to you to have the brush replaced
	Check the state of wear of the splashguard rubber blade	 ATTENTION: if the condition of the splashguard rubber blade does not allow the detergent solution to be collected and conveyed into the machine, contact your service centre of reference or the one closest to you to have it replaced
3	Check the condition of the discharge pipe of the recovery tank	 ATTENTION: if the condition of the recovery tank drainage hose does not meet the standard (there are leaks or cuts), contact your service centre of reference or the one closest to you to have it replaced
4	Check the condition of the solution tank cap - filter	 ATTENTION: if the condition of the solution tank cap-filter does not meet the standard, contact your service centre of reference or the one closest to you to have it replaced
5	Battery-powered supply system	 ATTENTION: refer to the owner's manual of the supplier of the batteries used for battery maintenance.

MAINTENANCE AFTER 100 WORKING HOURS

Ref.	Description	Notes
6	On-board battery charger system	 ATTENTION: for maintenance of the on-board battery charger, refer to the use and maintenance manual provided by the battery charger manufacturer. This document is delivered with the machine documentation (or contact your service centre of reference or the one closest to you to have it sent)

ROUTINE MAINTENANCE

Before carrying out any routine maintenance operations, proceed as follows:

1. Take the machine to the maintenance area.

⚠ WARNING: the place designated for this operation must comply with current regulations concerning safety at work and current environmental protection regulations.

2. Make sure the machine is in a safe condition - see "MACHINE SAFETY".

🧤 CAUTION: it is recommended to wear the appropriate PPE (Personal Protective Equipment), suitable for the work to be carried out.

CLEANING THE SQUEEGEE

The careful cleaning of the whole vacuum unit ensures better drying and cleaning of the floor as well as a longer vacuum motor life.

To clean the squeegee, proceed as follows:

1. Remove the suction hose from the squeegee nozzle.
2. Completely loosen the knobs on the squeegee pre-assembly.
3. Remove the squeegee via the slits in the squeegee connection.

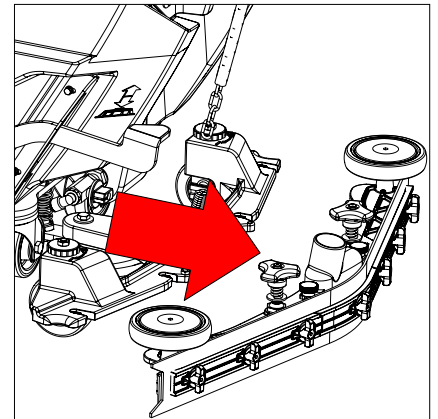
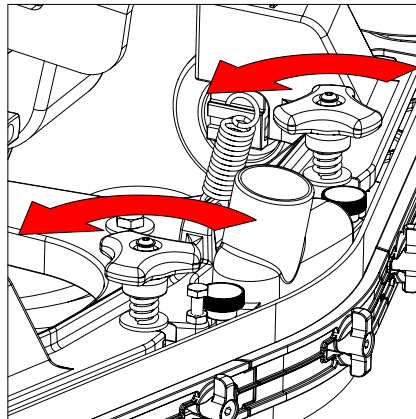
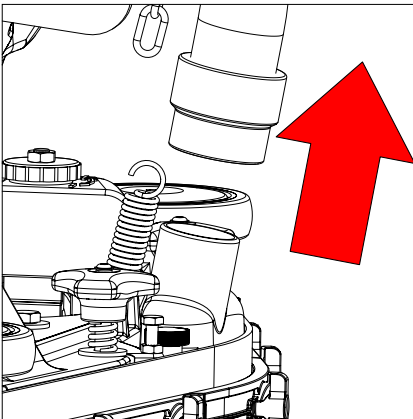

4. Thoroughly clean the vacuum chamber with a jet of water, and then with a damp cloth.

i N.B.: the vacuum chamber is to be understood as the portion of the squeegee unit located between the front squeegee rubber blade and the rear squeegee rubber blade.

i N.B.: if the dirt persists, use a brush with medium hardness bristles.

5. Thoroughly clean the rear rubber blade with a jet of water, and then with a damp cloth.
6. Thoroughly clean the front rubber blade with a jet of water, and then with a damp cloth.

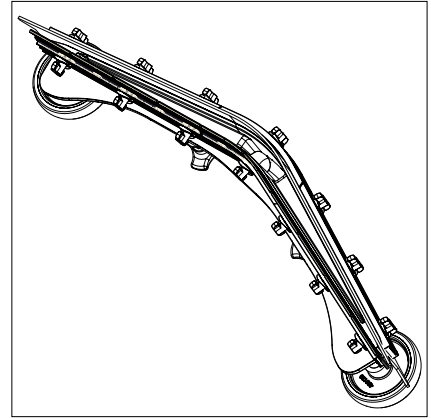
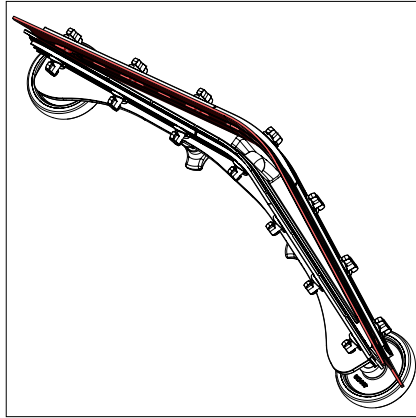
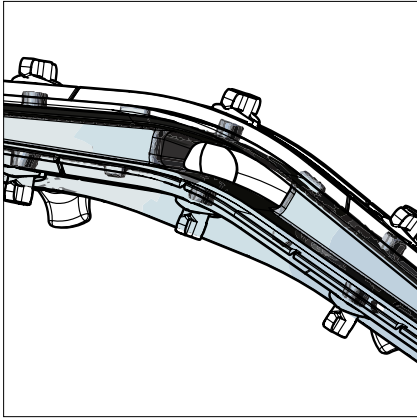

i **N.B.:** Check that the two rubber blades are in good condition; if necessary, replace the squeegee rubber blades, refer to .

7. Completely loosen the knobs on the squeegee pre-assembly.
8. Remove the vacuum nozzle from the squeegee body.
9. Thoroughly clean the vacuum nozzle intake chamber with a jet of water, and then with a damp cloth.

i **N.B.:** if the dirt persists, use a brush with medium hardness bristles.

10. Proceed in the opposite order to reassemble all the parts.

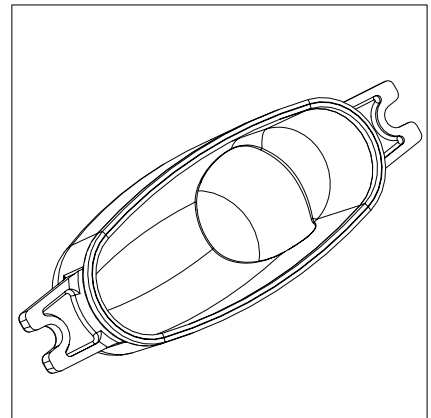
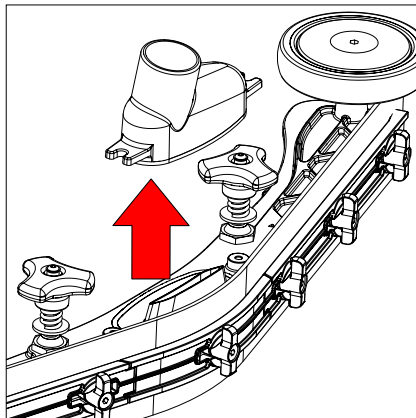
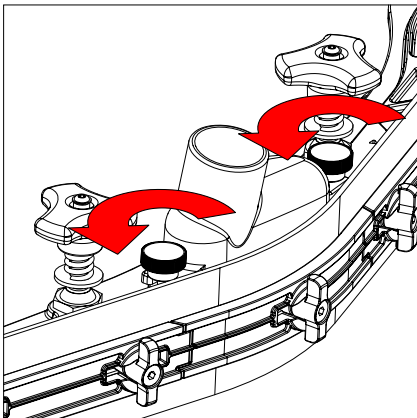

CLEANING THE SQUEEGEE VACUUM HOSE

The thorough cleaning of the squeegee vacuum hose guarantees better cleaning and drying of the floor, as well as a longer life for the suction motor.

To clean the squeegee vacuum hose, do the following:

1. Remove the suction hose from the squeegee nozzle.
2. Place the hose over the drain pan.

N.B.: discharges into the subsoil resulting from any work activities must only be carried out in designated areas; they must also be performed in compliance with the environmental regulations in force in the machine's country of use.

3. Grip the handle on the recovery tank cover and turn the cover to its maintenance position.
4. Remove the waste collection tray.

5. Rinse the inside of the vacuum hose with a jet of running water.

i **N.B.:** the water jet must be directed into the duct in the recovery tank.

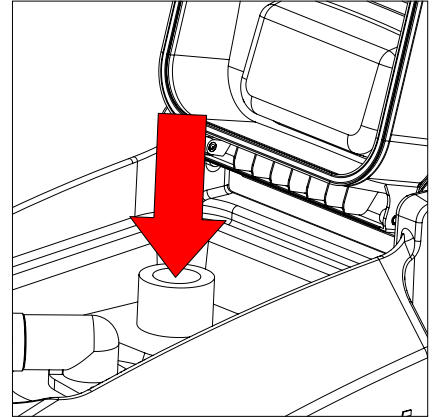
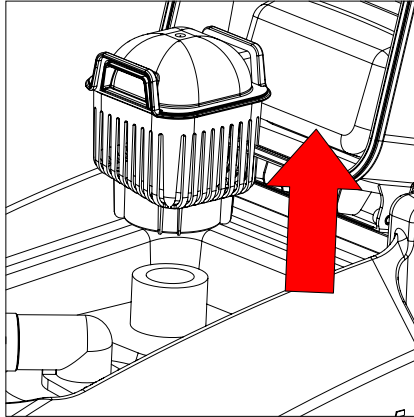
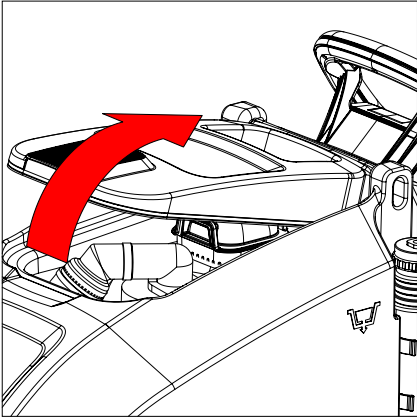

6. Repeat the operations in reverse order to reassemble all the parts.

DRAINING THE RECOVERY TANK

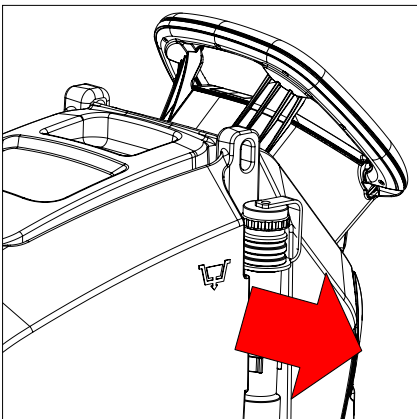

Thoroughly cleaning the recovery tank will prevent unpleasant odours from forming inside. To clean the tank, do the following:

1. Remove the recovery tank drainage hose from its retainers.
2. Place the hose over the drain pan.



N.B.: discharges into the subsoil resulting from any work activities must only be carried out in designated areas; they must also be performed in compliance with the environmental regulations in force in the machine's country of use.

Versions with drain pipe without tap:

- Bend the end of the drain pipe to create a bottleneck and prevent the contents from leaking out, place the pipe on the drain surface.
- Gradually unscrew the cap in the exhaust pipe.
- Wait until the recovery tank is completely empty.

Versions with ball valve exhaust pipe:

- Place the tube on the drain surface.
- Gradually rotate the lever in the ball valve.
- Wait until the recovery tank is completely empty.

3. Clean the inside of the recovery tank well with a jet of water.

i **N.B.:** if dirt persists, use a spatula.

4. Proceed in the opposite order to reassemble all the parts.

RECOVERY TANK CLEANING

Careful cleaning of the waste collector tray inside the recovery tank helps to reduce the formation of unpleasant odours inside it. To carry out the cleaning of the waste tray carry out the following:

1. Check that the recovery tank is empty; if it isn't, drain it. See "EMPTYING THE RECOVERY TANK".
2. Grip the handle on the recovery tank cover and turn the cover to its maintenance position.
3. Remove the waste collection tray.
4. Clean the tray and cover under a stream of running water.

i **N.B.:** Use a spatula or a brush with medium hardness bristles to eliminate any dirt that is particularly difficult to remove.

5. Use a cloth to dry the collection filter tray and lid, and place them back inside the recovery tank.
6. Repeat the operations in reverse order to reassemble all the parts.

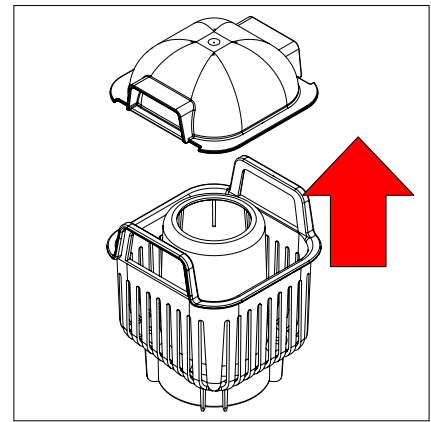
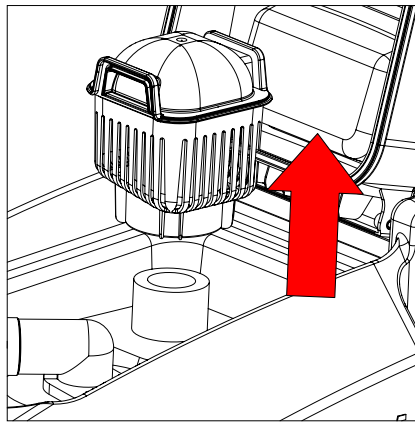
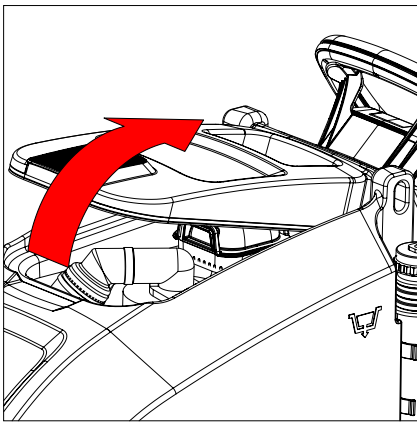

CLEANING OF THE SUCTION MOTOR AIR INTAKE FILTER

Thorough cleaning of the suction motor air inlet filter ensures better functionality and duration of the suction motor. To clean the suction motor air inlet filter, proceed as follows:

1. Check that the recovery tank is empty; if it isn't, drain it. See "EMPTYING THE RECOVERY TANK".
2. Grip the handle on the recovery tank cover and turn the cover to its maintenance position.
3. Remove the guard from the suction motor filter, then rotate the guard and remove it.
4. Remove the suction motor filter from its support.

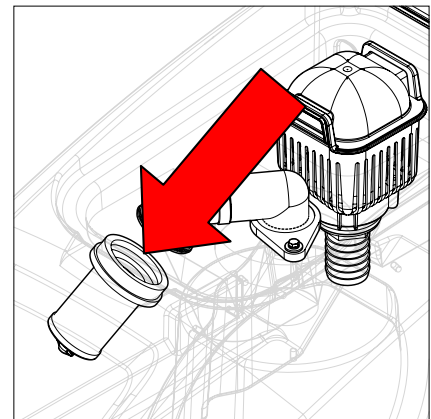
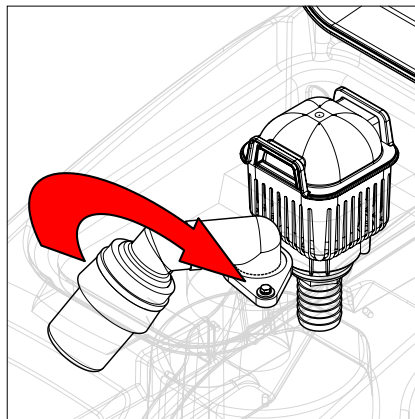
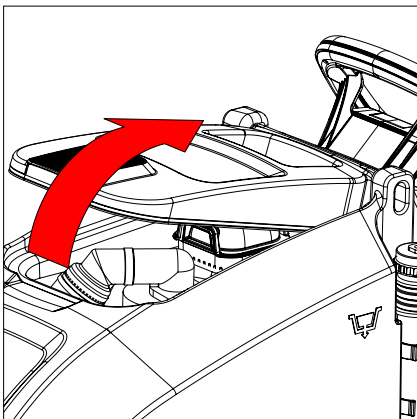

5. Clean the suction motor inlet air filter with a stream of running water.
6. Clean the filter protection with a stream of running water.

i **N.B.:** if the dirt persists, use a brush with medium hardness bristles.

7. Repeat the operations in reverse order to reassemble all the parts.

CLEANING THE BRUSH - PAD HOLDER

The thorough cleaning of the brush or the drive disc on the brush head will ensure better floor cleaning, thus decreasing costs while at the same time improving environmental sustainability and performance.

1. Stand at the back of the machine.
2. Check the main switch is on "0"; if it isn't, make a quarter turn anti-clockwise with the key.
3. Remove the key from the instrument panel.
4. Grip the handle and turn the recovery tank to its maintenance position.

⚠ ATTENTION: to prevent the recovery tank from rotating accidentally, turn it until the retainer cable is fully tensioned.

⚠ ATTENTION: the following operations must be carried out by qualified personnel. Incorrect operations could result in machine malfunctions.

5. Check the connector on the machine's electrical system wiring is connected to the connector on the power cable from the battery box. If it isn't, connect it.

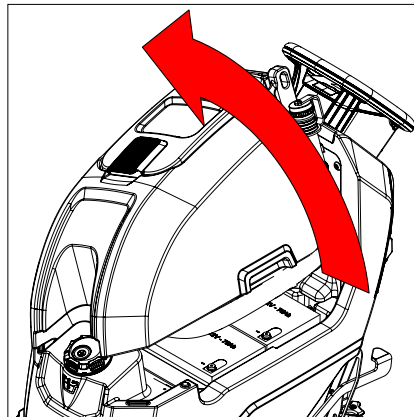
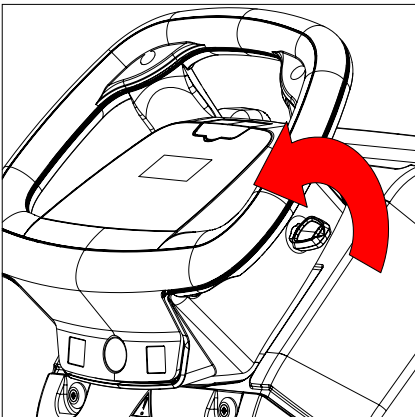

6. Grip the handle and turn the recovery tank to its working position.
7. Insert the key into the instrument panel.
8. Switch on the machine, making a quarter turn clockwise with the key.
9. Activate TRANSFER mode - see "TRANSFER WORKING MODE".
10. Activate the brush uncoupling function - see "BRUSH UNCOUPLING FUNCTION".
11. Make sure the machine is in a safe condition - see "MACHINE SAFETY".
12. After removing the brush or pad holder, clean it under a jet of water to eliminate any impurities from the bristles.

i **N.B.:** check the wear of the bristles and replace the brushes if they are excessively worn (the bristle length must not be less than 10 mm; this measurement is indicated on the brush by a yellow band). See "REPLACING THE BRUSHES OR PAD HOLDERS".

13. After cleaning, refit the brush - see "ASSEMBLING THE BRUSHES OR PAD HOLDERS".

CLEANING THE BRUSH HEAD SPLASH GUARD

The thorough cleaning of the brush head splash guard allows the cleaning solution to be better directed towards the centre of the machine so that it can be collected by the squeegee, thereby increasing cost savings and increasing environmental sustainability.

To clean the brush head squeegee, proceed as follows:

1. Go to the front right of the machine.
2. Release the blade that secures the splash guard, using the hook to facilitate the operation.
3. Remove the blade from the machine.
4. Remove the splash guard from the machine.
5. Thoroughly clean the splash guard with a stream of running water, and then with a damp cloth.
6. To refit, repeat the operations for removal but in the reverse order.

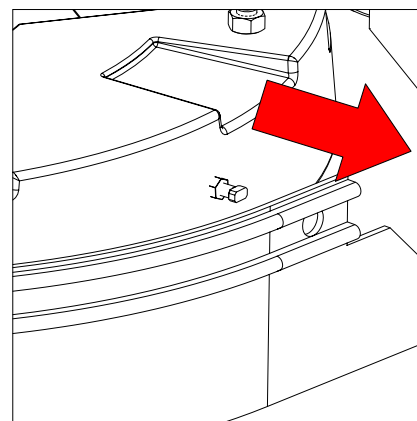
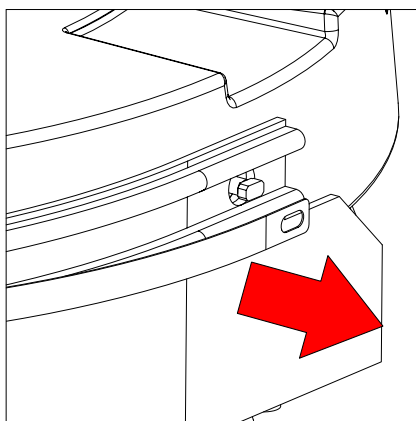
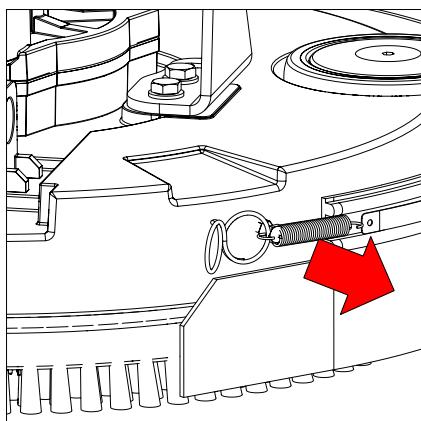

EMPTYING THE SOLUTION TANK

Thoroughly cleaning the solution tank will prevent unpleasant odours from forming inside. To clean the tank, do the following:

1. Remove the filler cap at the front of the machine.
2. Tighten the detergent solution tap.
3. Remove the filter cap at the rear of the machine.

 **N.B.:** discharges into the subsoil resulting from any work activities must only be carried out in designated areas; they must also be performed in compliance with the environmental regulations in force in the machine's country of use.

4. Rinse the inside of the solution tank with a jet of running water.
5. Repeat the operations in reverse order to reassemble all the parts.

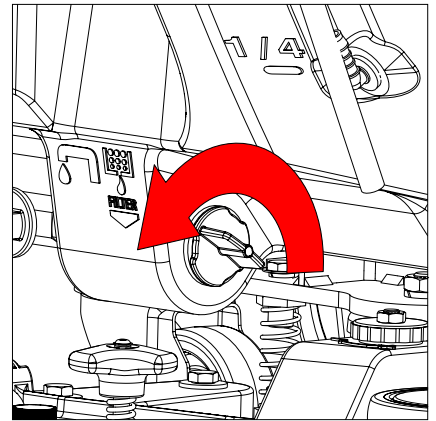
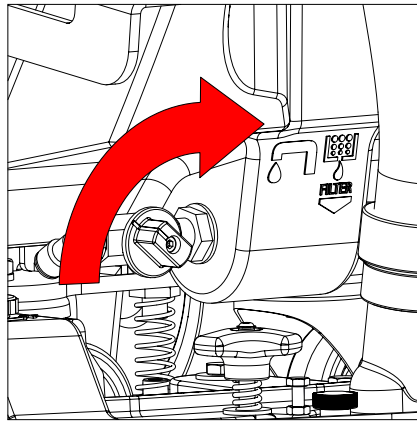
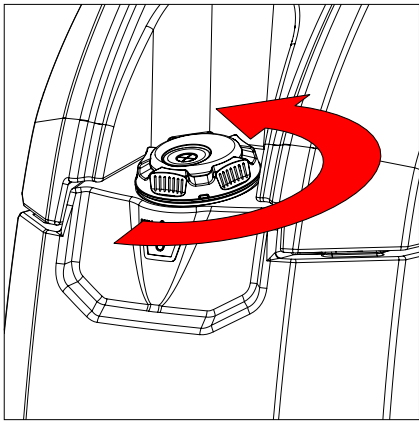

i **N.B.:** before screwing the cap onto the solution tank, check that the gasket is positioned correctly in the cap.

CLEANING THE SOLUTION TANK FILTER-CAP

Thorough cleaning of the solution tank cap - filter ensures better cleaning of the floor, if the cap - filter is clogged the cleaning solution does not circulate in the water system of the machine, thereby increasing cost savings and an increase in environmental eco sustainability.

To carry out the cleaning of the solution tank filter - cap, proceed as follows:

1. Remove the filler cap at the front of the machine.
2. Tighten the detergent solution tap.
3. Remove the filter cap at the rear of the machine.
4. Clean the cap - filter with a stream of running water.

i **N.B.:** if the dirt persists, use a brush with medium hardness bristles.

5. Repeat the operations in reverse order to reassemble all the parts.

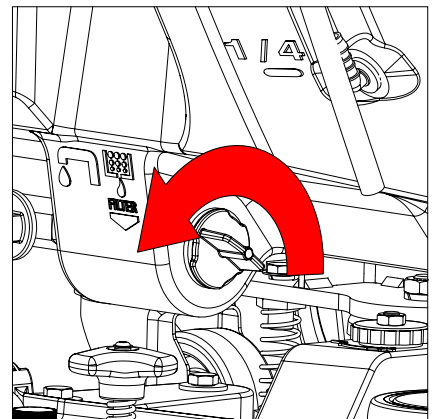
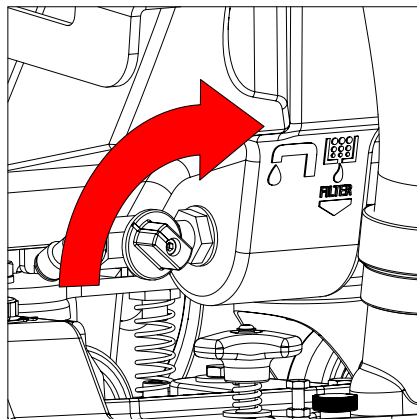
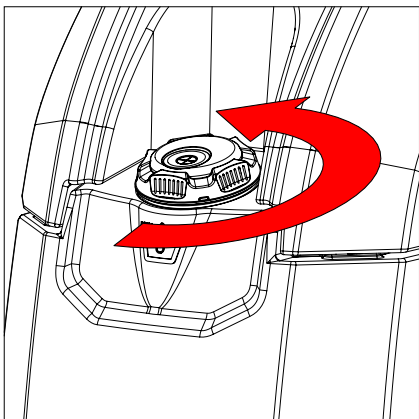

i **N.B.:** before screwing the cap onto the solution tank, check that the gasket is positioned correctly in the cap.

EXTRAORDINARY MAINTENANCE WORK

Before carrying out any extraordinary maintenance operations, proceed as follows:

1. Take the machine to the maintenance area.

WARNING: the place designated for this operation must comply with current regulations concerning safety at work and current environmental protection regulations.

2. Make sure the machine is in a safe condition - see "MACHINE SAFETY".

CAUTION: it is recommended to wear the appropriate PPE (Personal Protective Equipment), suitable for the work to be carried out.

REPLACING THE SQUEEGEE RUBBER BLADES

Intact squeegee rubber blades will ensure better floor cleaning, thus decreasing costs while at the same time improving environmental sustainability and performance.

To replace the squeegee rubber blades, do the following:

1. Remove the suction hose from the squeegee nozzle.
2. Completely loosen the knobs on the squeegee pre-assembly.
3. Remove the squeegee via the slits in the squeegee connection.

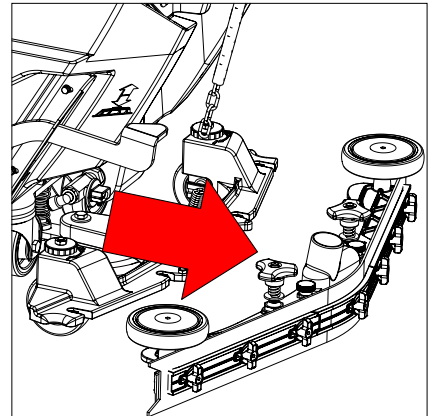
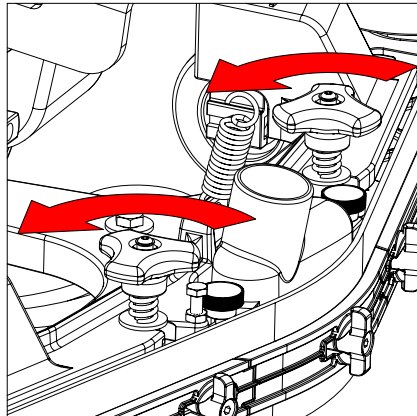
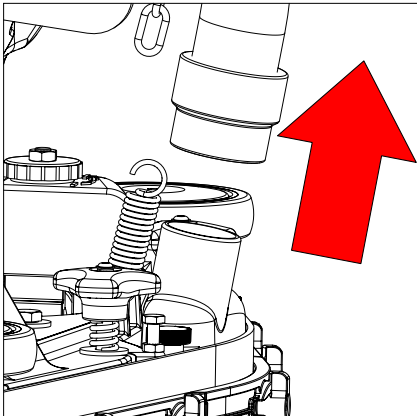

N.B.: it is advised to replace both squeegee rubber blades in order to ensure good results when drying the floor.

4. Turn the knobs to the horizontal position.
5. Remove the rubber-pressing blade and rear rubber blade from the squeegee.
6. Replace the worn rear rubber blade with the new one.
7. Position the new rear rubber blade in the squeegee and secure it in place using the rubber-pressing blade.
8. Lock the rubber-pressing blade by turning the knobs to the vertical position.

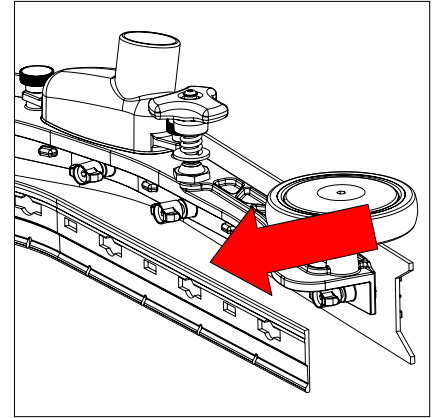
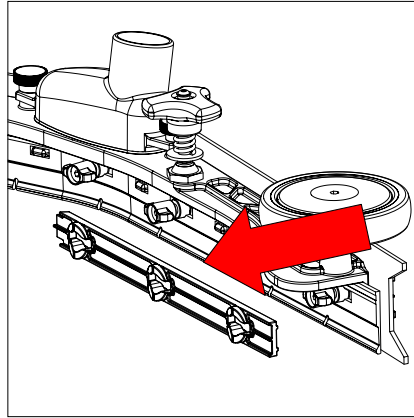
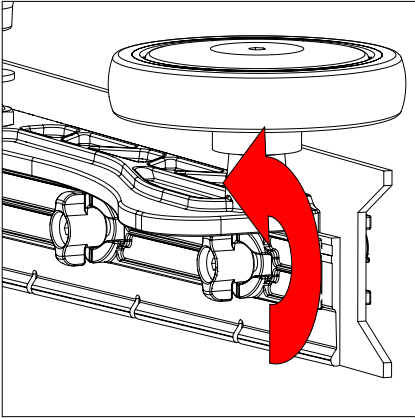

9. Turn the knobs to the horizontal position.
10. Remove the rubber-pressing blade and front rubber blade from the squeegee.
11. Replace the worn front rubber blade with the new one.
12. Position the new front rubber blade in the squeegee and secure it in place using the rubber-pressing blade.
13. Lock the rubber-pressing blade by turning the knobs to the vertical position.

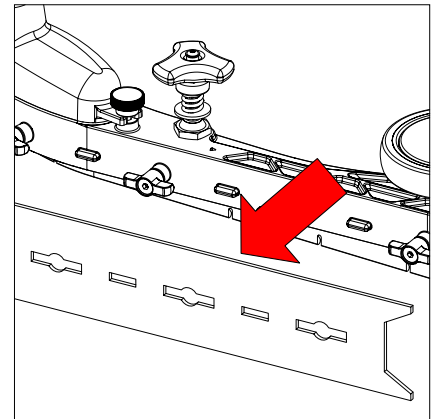
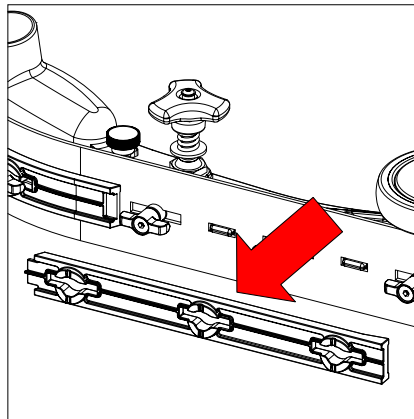
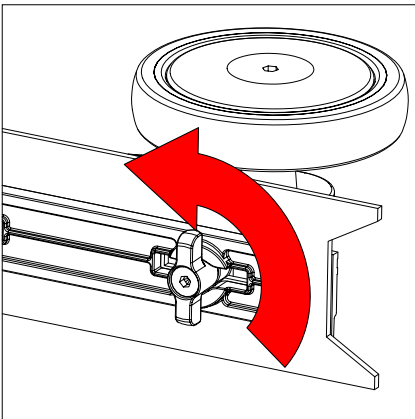

14. After both squeegee rubber blades have been replaced, attach the squeegee to the squeegee support in the machine. See "[ASSEMBLING THE SQUEEGEE UNIT](#)" on page 70.

- i** **N.B.:** check the adjustment of the rubber blades in the squeegee. If necessary, refer to "[SQUEEGEE RUBBER BLADES ADJUSTMENT](#)" on page 70.
- i** **N.B.:** it is advised to replace both squeegee rubber blades in order to ensure good results when drying the floor.

REPLACING THE BRUSHES OR PAD HOLDERS

Ensuring the brush or the drive disc on the brush head is intact will ensure better floor cleaning, thus decreasing costs while at the same time improving environmental sustainability and performance.

1. Stand at the back of the machine.
2. Check the main switch is on "0"; if it isn't, make a quarter turn anti-clockwise with the key.
3. Remove the key from the instrument panel.
4. Grip the handle and turn the recovery tank to its maintenance position.

 **ATTENTION:** to prevent the recovery tank from rotating accidentally, turn it until the retainer cable is fully tensioned.

 **ATTENTION:** the following operations must be carried out by qualified personnel. Incorrect operations could result in machine malfunctions.

5. Check the connector on the machine's electrical system wiring is connected to the connector on the power cable from the battery box. If it isn't, connect it.

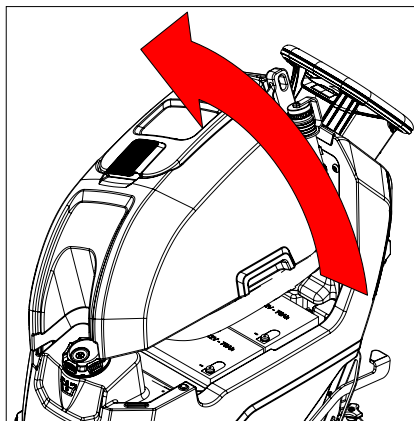
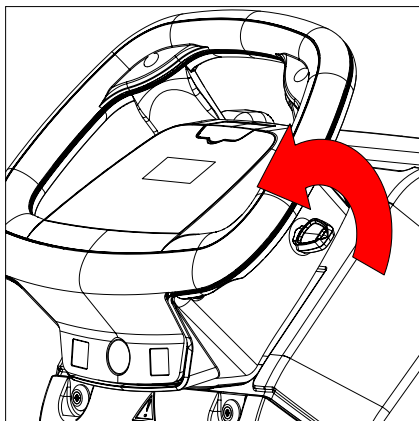

6. Grip the handle and turn the recovery tank to its working position.
7. Insert the key into the instrument panel.
8. Switch on the machine, making a quarter turn clockwise with the key.
9. Activate TRANSFER mode - see "TRANSFER WORKING MODE".
10. Activate the brush uncoupling function - see "BRUSH UNCOUPLING FUNCTION".
11. Make sure the machine is in a safe condition - see "MACHINE SAFETY".
12. Remove the brush and replace it with a new one - see "ASSEMBLING THE BRUSHES OR PAD HOLDERS".

REPLACING THE HEPA FILTER ON THE SUCTION MOTOR AIR OUTLET

Thorough cleaning of the HEPA air filter on the suction motor outlet is important because it guarantees a higher degree of comfort for users, by lowering the degree of air purification; proper filtration is synonymous with well-being for the people working - or simply in - a certain place.

To replace the HEPA filter, proceed as follows:

1. Grip the handle and turn the recovery tank to its maintenance position.



WARNING: to prevent the recovery tank from rotating accidentally, turn it until the retainer cable is fully tensioned.

2. Remove the old HEPA outlet air filter and replace it with the new one.
3. Grip the handle and turn the recovery tank to its working position.

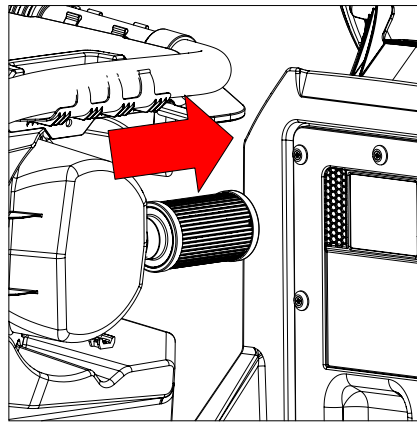
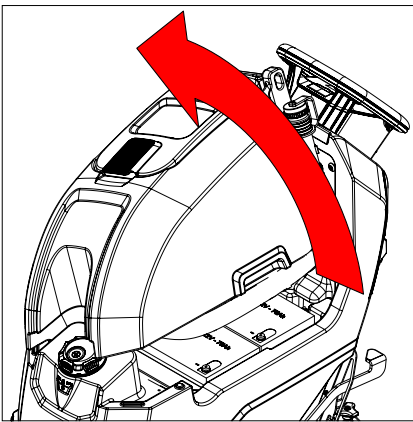

ADJUSTMENT INTERVENTIONS

ADJUSTING THE SQUEEGEE RUBBER BLADES

The precise adjustment of the squeegee rubber blades will ensure better floor cleaning, thus decreasing costs while at the same time improving environmental sustainability and performance.

To regulate the squeegee rubber blades, proceed as follows:

1. Switch on the machine, making a quarter turn clockwise with the key.
2. Bring the brush head to its working position (in contact with the floor). For basic versions, press the brush head control pedal all the way down and then shift it to the left before releasing it. For pro versions, press the brush

head control button  on the control panel.

 **N.B.:** when the brush head is in the working position, the LED in the button is ON.

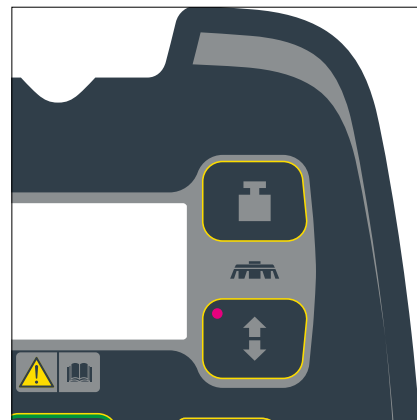
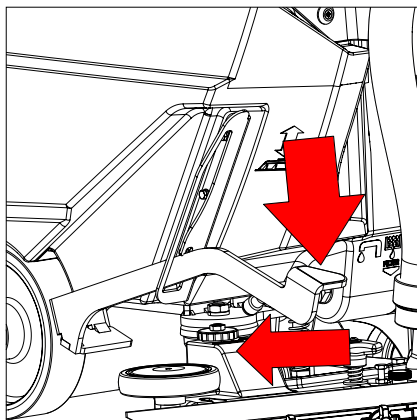
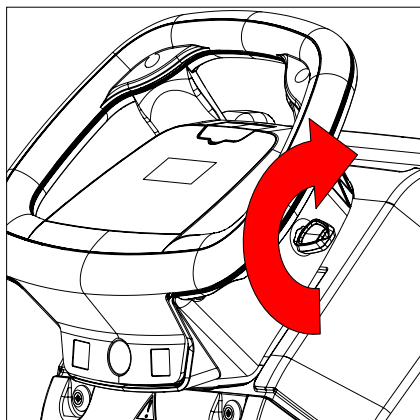



3. Bring the squeegee to the working position (in contact with the floor) by rotating the lever at the back of the machine downwards.
4. The machine is now in scrubber working mode.

 **CAUTION:** it is recommended to wear the appropriate PPE (Personal Protective Equipment), suitable for the work to be carried out.

5. Stand at the back of the machine.
6. Adjust the height of the rubber blade in relation to the floor by tightening or loosening the yellow knobs on the squeegee support.

 **N.B.:** turning them anti-clockwise reduces the distance between the squeegee support and the floor, whereas turning them in the opposite direction increases it.

 **N.B.:** By decreasing the distance between the squeegee support and the floor, the rubber blades present in the squeegee move closer to the floor.

 **N.B.:** The right-hand and left-hand knobs must be rotated the same number of times, so that the squeegee is parallel to the floor when it is working.

7. Using the specific tool (not included with the machine), loosen the locknut of the squeegee inclination adjustment screw.

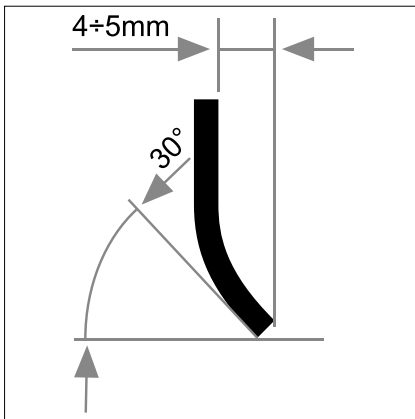
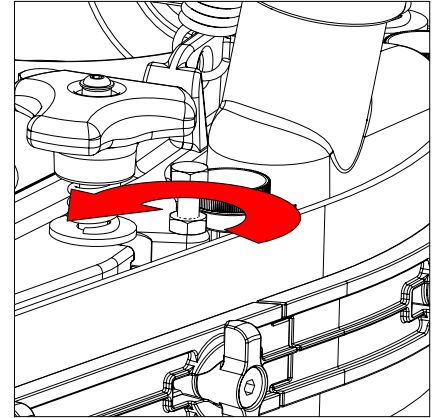
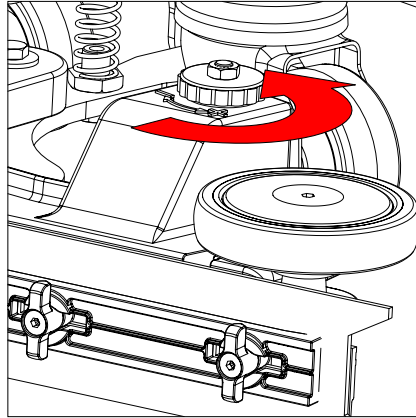
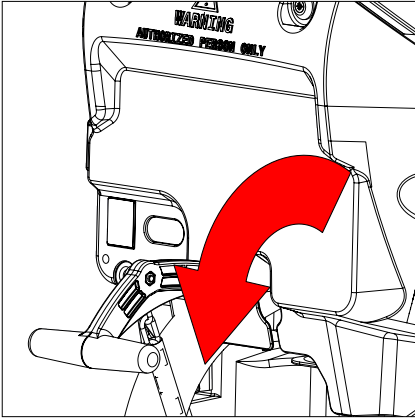

8. Adjust the tilt of the squeegee rubber blades (they must be bent outwards by about 30° in relation to the floor, in an even manner along their entire length) by tightening or loosening the adjustment screw.

9. As soon as the adjustment has been made, tighten the lock nut.

DISPOSAL

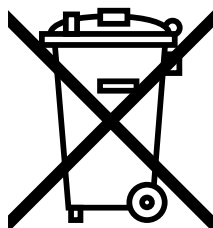

Fimap is committed to creating its products by respecting the environment, investing in the development of sustainable solutions and technologies, seeking materials that can easily be recycled, and ensuring that the entire production process has a low environmental impact.

At the end of the machine's life cycle, FIMAP offers the RECYCLING MANUAL (which can be downloaded from the link <https://www.fimap.com/it/fimap/sostenibilita/75/riciclabilita.html>), in order to provide some simple information on how to dispose of the materials that make up your scrubbing machine.



ATTENTION: Before proceeding with disposal, it is essential to contact your nearest authorised collection centres directly, in accordance with the legislation in force in the country where the machine is used.

CHOOSING AND USING BRUSHES

All the brushes are comprised of a body to which the various tufts of bristles are fixed. The brush bodies are generally made of plastic, as this is a material that ensures higher levels of reliability, in that it does not become damaged when wet.

i N.B.: when the bristle starts to be consumed, it comes closer to the brush and increases its rigidity, losing its flexibility characteristics that allows it to collect and remove dirt. For this reason it is important to replace them at the right moment.

The type of brushes for scrubbing machines can be chosen according to the material the bristles are made of; the most common bristle materials are as follows:

POLYPROPYLENE (PPL)	NYLON (PA)	TYNEX
Synthetic polymer	Synthetic polymer	Very durable abrasive material
Bristles with varying level of abrasion and thickness (0.3÷1.5 mm)	Can be used as an alternative to PPL	Can be used for deep cleaning on industrial surfaces
Can be used on any type of flooring		
Can be used for routine or deep cleaning		

UNION MIX	STEEL
Compound based on natural products	Suitable for industrial floors with stubborn dirt
Can be used for polishing and scrubbing activities	Alternative to Tynex
Resistant to very high temperatures	
Subject to rapid wear, shorter life than the PPL version	
Must be used with non-aggressive detergents	
Suitable for flooring types such as: marble; granite; porphyry cobbles; terracotta	
Not suitable for cleaning heavy soiling	

As an alternative to brushes, drive discs can be used. They consist of the rigid brush body without the bristles, which are replaced by pads.

PADS
Ideal for both regular and non-routine cleaning
Perfect for porcelain floors; tuff or microporous surfaces
Ideal for resin floors; cement floors; polishing operations
Not suitable for uneven floors with joints

PAD colour according to the work to be done

COLOUR	TYPE OF WORK
White	The white abrasive pad, is ideal for dry polishing of unprotected floors with standard speed machines, Also suitable for spray cleaning operations. They improve shine without scratching or damaging protected pavements.
Yellow/white	The yellow/white abrasive pad restores shine to dulled floors in a single pass. They optimize the action of high-speed machinery on a wide range of finishes, minimizing the effect of abrasion.
Brown	The brown abrasive pad is suitable for both dry de-waxing of protected floors and wet de-waxing with a standard chemical de-waxer. The open weave structure of these washable and reusable discs prevents clogging and material build-up. The combination of highly adaptable, individually separated and coated fibres promotes maximum contact between disc and floor, ensuring excellent cleaning results at low cost.
Black	The black abrasive pad is suitable for total wet de-waxing of hard surfaces with de-waxing chemicals and standard speed machines. The open weave structure of these washable and reusable discs prevents clogging and material build-up. The even distribution of the mineral abrasives over the entire disc, and not only on the surface, guarantees outstanding performance and a long product life. The combination of highly adaptable, individually separated and coated fibres promotes maximum contact between disc and floor, ensuring excellent cleaning results at low cost.
Ochre	The ochre-coloured abrasive pad is designed to reduce imperfections on damaged marble and resilient surfaces.
Red	The red abrasive pad is designed for spray cleaning and regular maintenance operations on protected surfaces. These discs exert a cleaning action when wet and an abrasive action when used dry. The open weave structure of these washable and reusable discs prevents clogging and material build-up. The even distribution of the mineral abrasives over the entire disc, and not only on the surface, guarantees outstanding performance and a long product life. The combination of highly adaptable, individually separated and coated fibres promotes maximum contact between disc and floor, ensuring excellent cleaning results at low cost. For use with standard-speed or high-speed machines.
Green	The green abrasive pad is suitable for partial wet debinding of unprotected hard surfaces. They can also be used to prepare hard surfaces before re-waxing and to completely de-wax flooring such as lino or vinyl. The open weave structure of these washable and reusable discs prevents clogging and material build-up. The combination of highly adaptable, individually separated and coated fibres promotes maximum contact between disc and floor, ensuring excellent cleaning results at low cost.
Burgundy	The burgundy-coloured abrasive pad is suitable for quick abrasive action to prepare a variety of surfaces for application of finishes.

BRUSHES OR PAD HOLDERS

Legend: \varnothing_E = external bristle diameter; \varnothing_F = external tank diameter (brush body)



Disc brush



Pad holder

MACHINE	CODE	QTY	\varnothing EXTERNAL	TYPE OF BRISTLE	\varnothing BRISTLES	NOTES
JMX 43	452403	1	430mm	PPL	0.3mm	Discoidal brush $\varnothing_e=430\text{mm}$ $\varnothing_f=410\text{mm}$ $\varnothing_i=170\text{mm}$ H=68mm bristle type PPL $\varnothing_s=0.3\text{mm}$ (LIGHT BLUE)
	452404	1	430mm	PPL	0.6mm	Discoidal brush $\varnothing_e=430\text{mm}$ $\varnothing_f=410\text{mm}$ $\varnothing_i=170\text{mm}$ H=68mm bristle type PPL $\varnothing_s=0.6\text{mm}$ (WHITE)
	452405	1	430mm	PPL	0.9mm	Discoidal brush $\varnothing_e=430\text{mm}$ $\varnothing_f=410\text{mm}$ $\varnothing_i=170\text{mm}$ H=68mm bristle type PPL $\varnothing_s=0.9\text{mm}$ (BLACK)
	452406	1	430mm	ABRASIVE	1mm	Discoidal brush $\varnothing_e=430\text{mm}$ $\varnothing_f=410\text{mm}$ $\varnothing_i=170\text{mm}$ H=68mm bristle type ABRASIVE $\varnothing_s=1\text{mm}$
	452407	1	430mm	TAMPICO	-	Discoidal brush $\varnothing_e=430\text{mm}$ $\varnothing_f=410\text{mm}$ $\varnothing_i=170\text{mm}$ H=68mm bristle type TAMPICO
	452414	1	410 mm	-	-	Pad holder $\varnothing_e=430\text{mm}$ $\varnothing_f=410\text{mm}$ $\varnothing_i=170\text{mm}$ screw centre lock (code 410575 GREEN)

MACHINE	CODE	QTY	Ø EXTERNAL	TYPE OF BRISTLE	Ø BRISTLES	NOTES
JMX 50	404654	1	508mm	PPL	0.3mm	Discoidal brush Øe=510mm Øf=495mm Øi=170mm H=68mm bristle type PPL Øs=0.3mm (LIGHT BLUE)
	405631	1	508mm	PPL	0.6mm	Discoidal brush Øe=510mm Øf=495mm Øi=170mm H=68mm bristle type PPL Øs=0.6mm (WHITE)
	404653	1	508mm	PPL	0.9mm	Discoidal brush Øe=510mm Øf=495mm Øi=170mm H=68mm bristle type PPL Øs=0.9mm (BLACK)
	405632	1	508mm	ABRASIVE	1mm	Discoidal brush Øe=510mm Øf=495mm Øi=170mm H=68mm bristle type ABRASIVE Øs=1mm
	449908	1	508mm	TAMPICO	-	Discoidal brush Øe=510mm Øf=495mm Øi=170mm H=68mm bristle type TAMPICO
		1				Pad holder Øf=495mm Øi=170mm screw centre lock (code 510575 GREEN)

TROUBLESHOOTING

THE MACHINE DOES NOT START

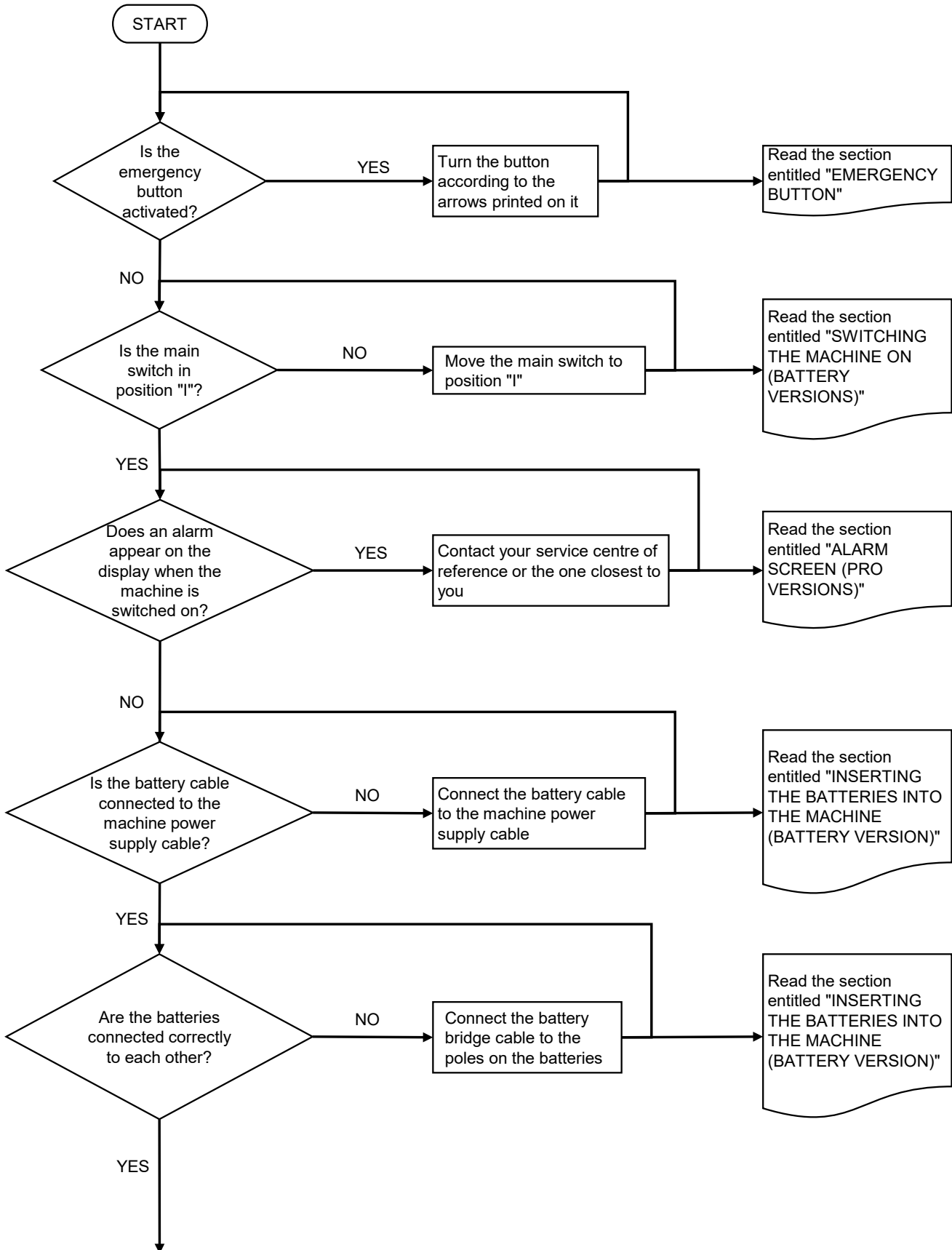

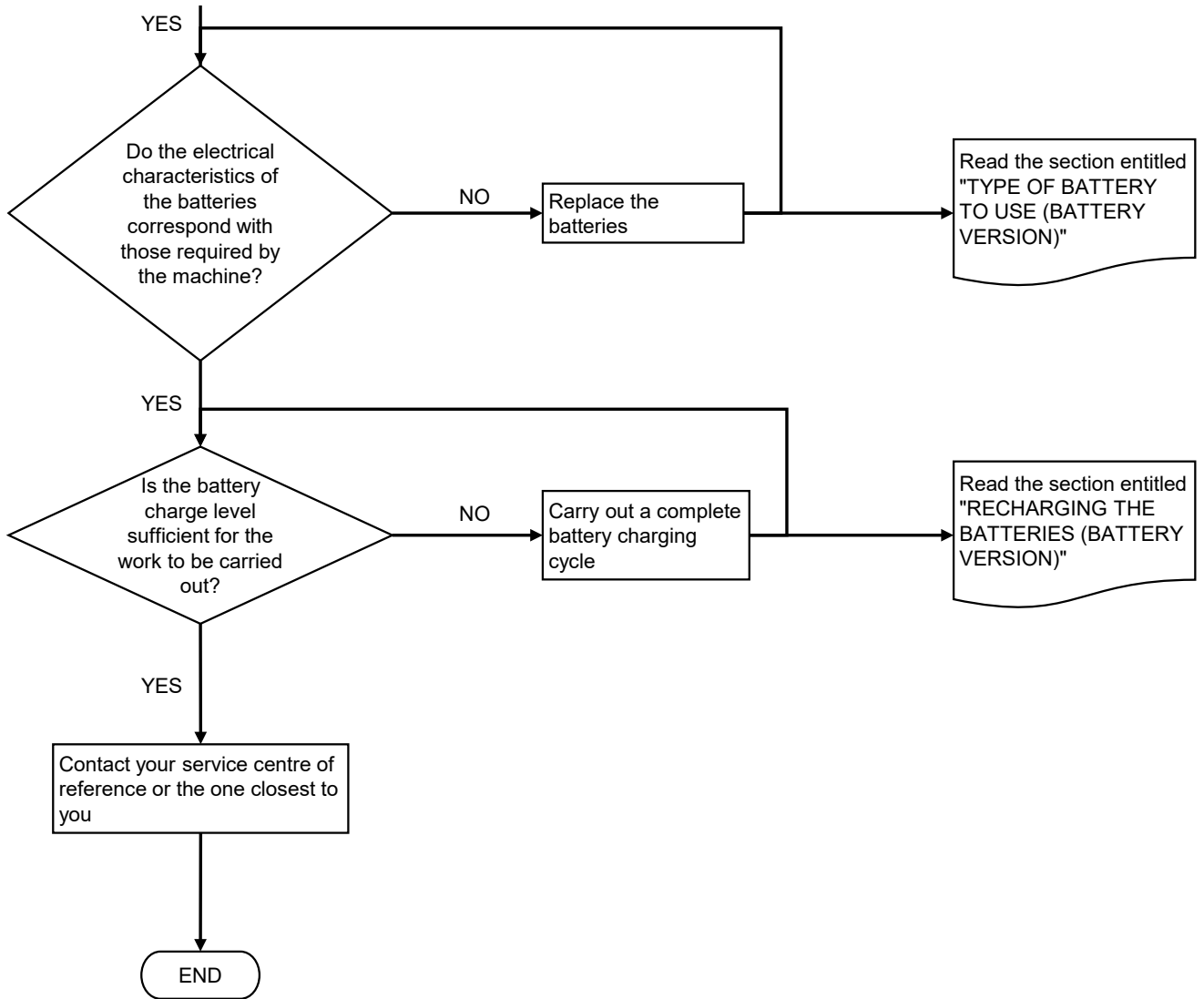

AN ERROR APPEARS ON THE CONTROL DISPLAY

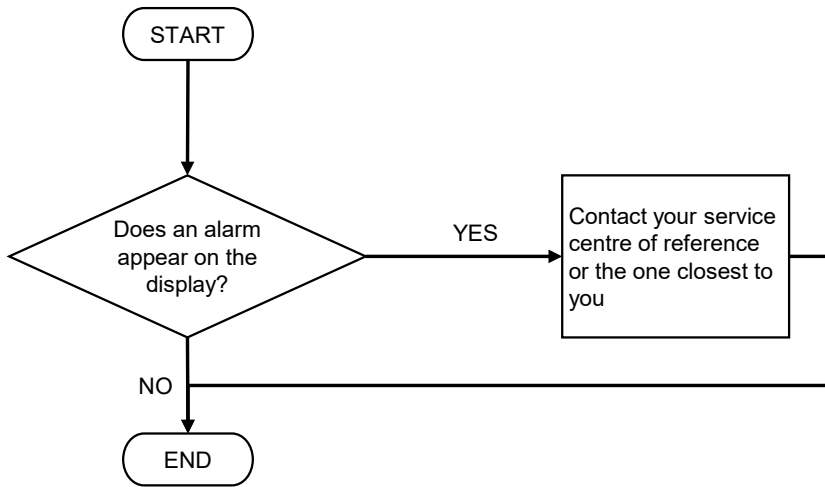

THE BATTERIES ARE NOT FULLY CHARGED

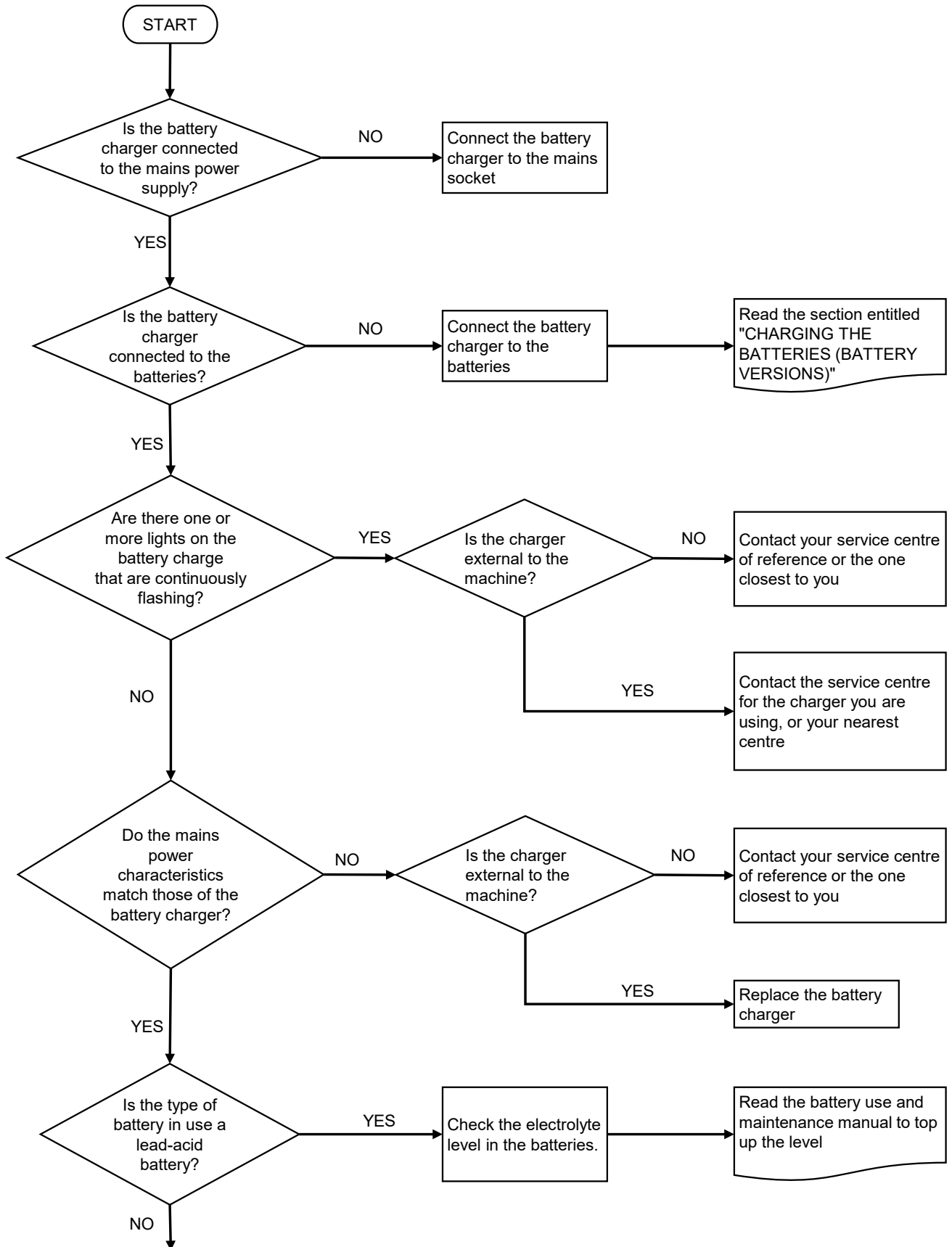

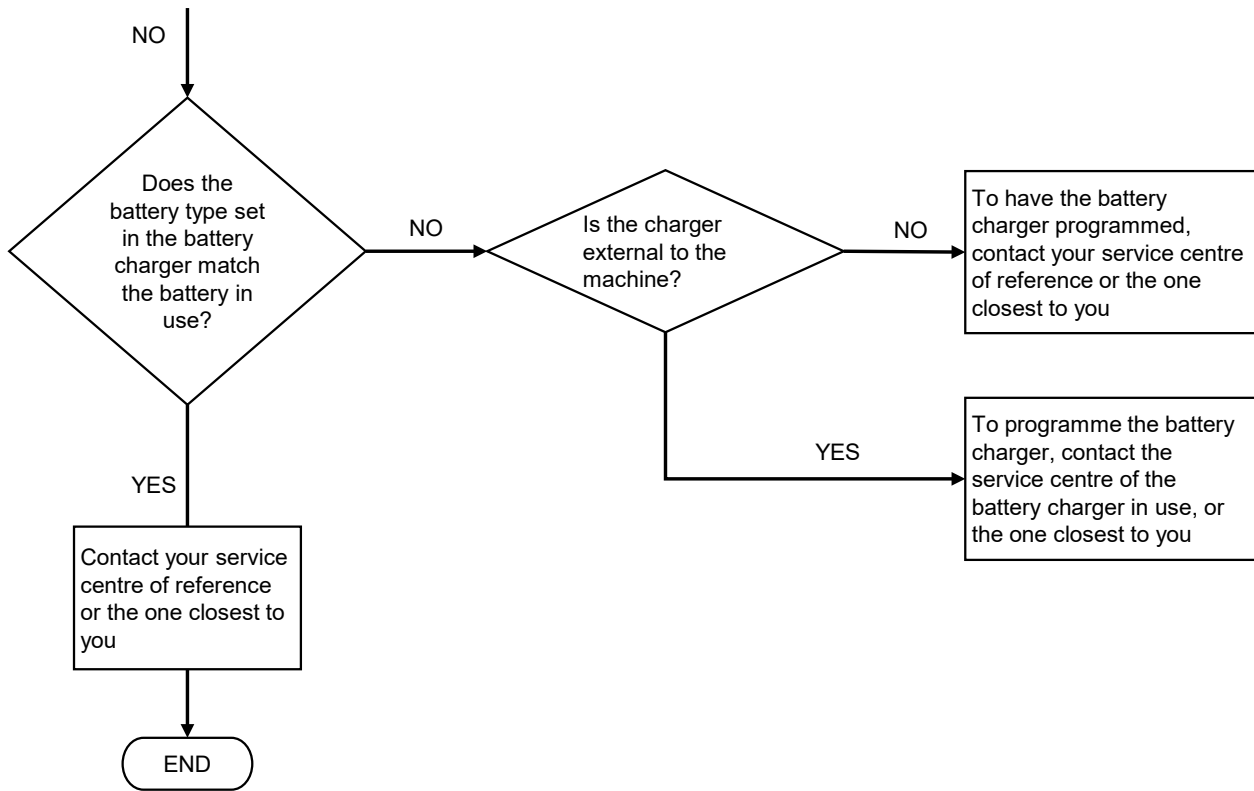

THE BATTERIES DO NOT WORK CORRECTLY

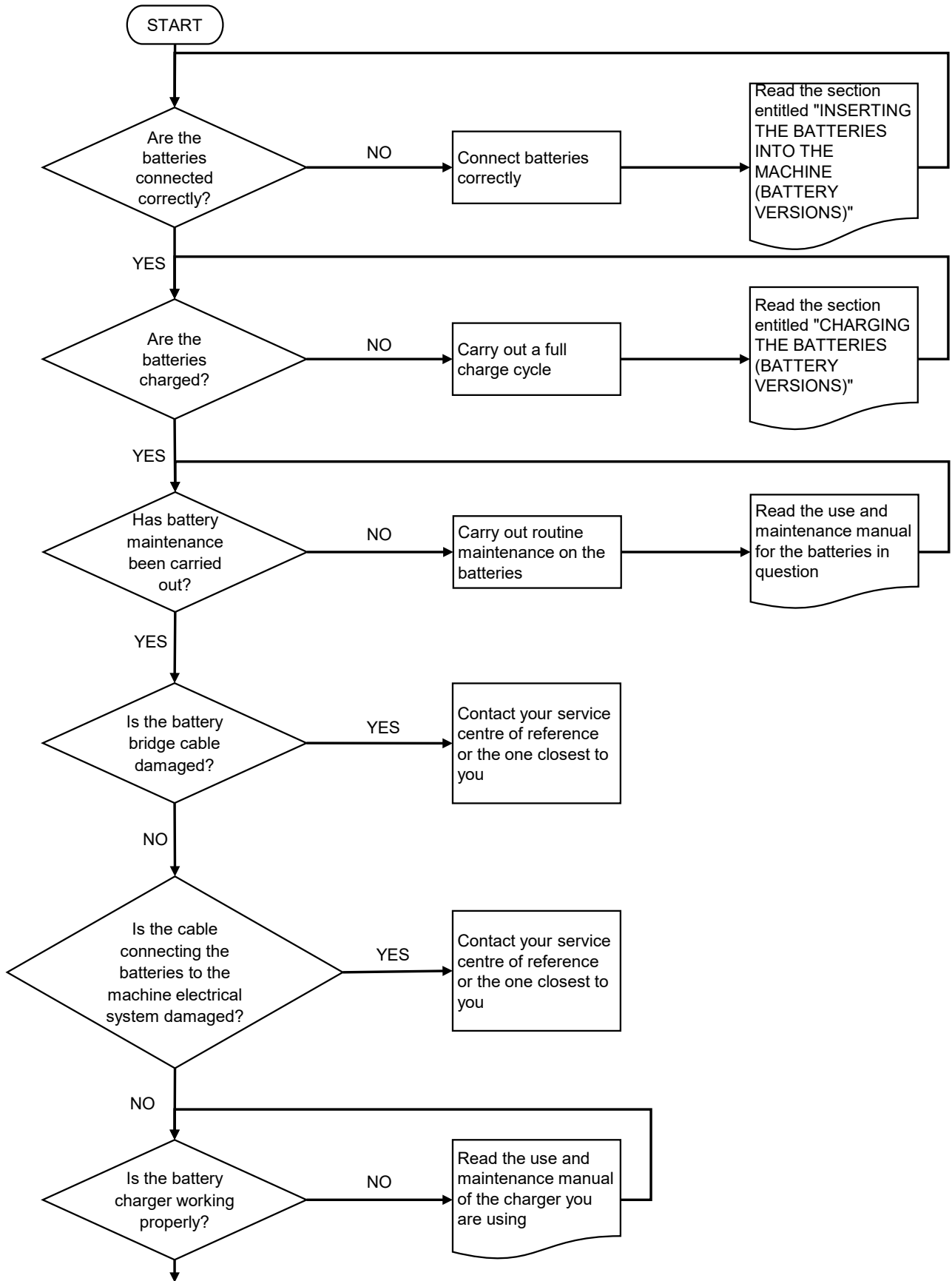

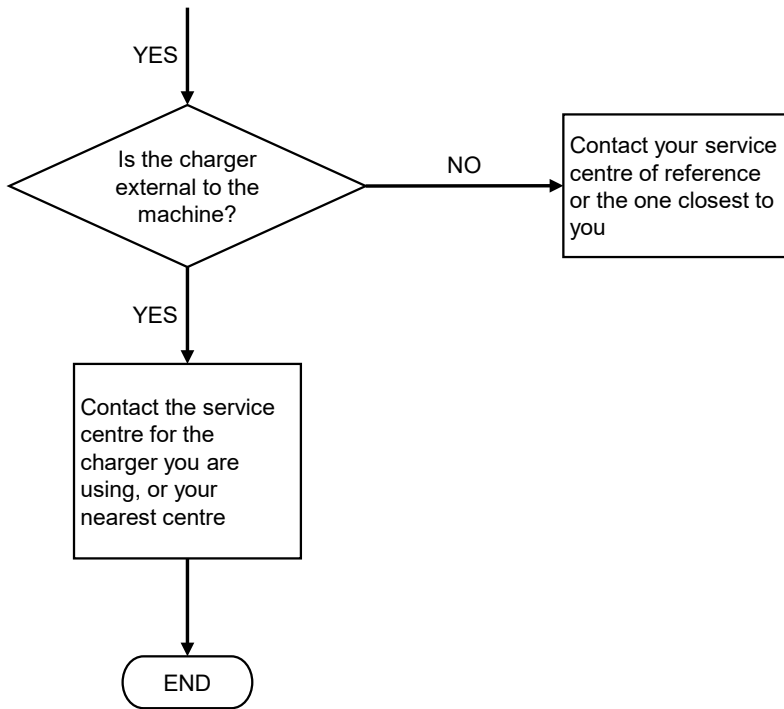

VERY LOW WORKING AUTONOMY

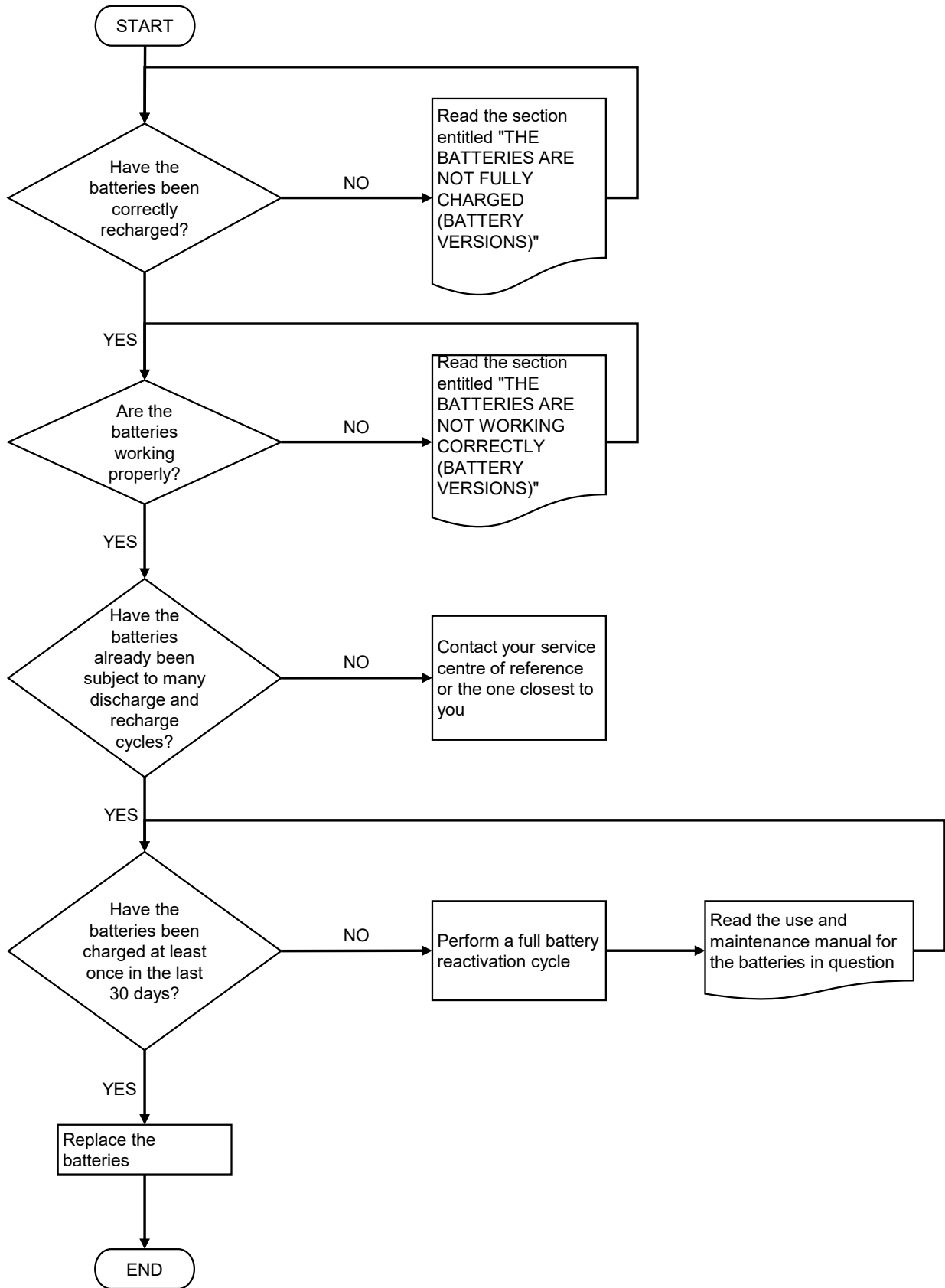

THE MACHINE DOES NOT MOVE

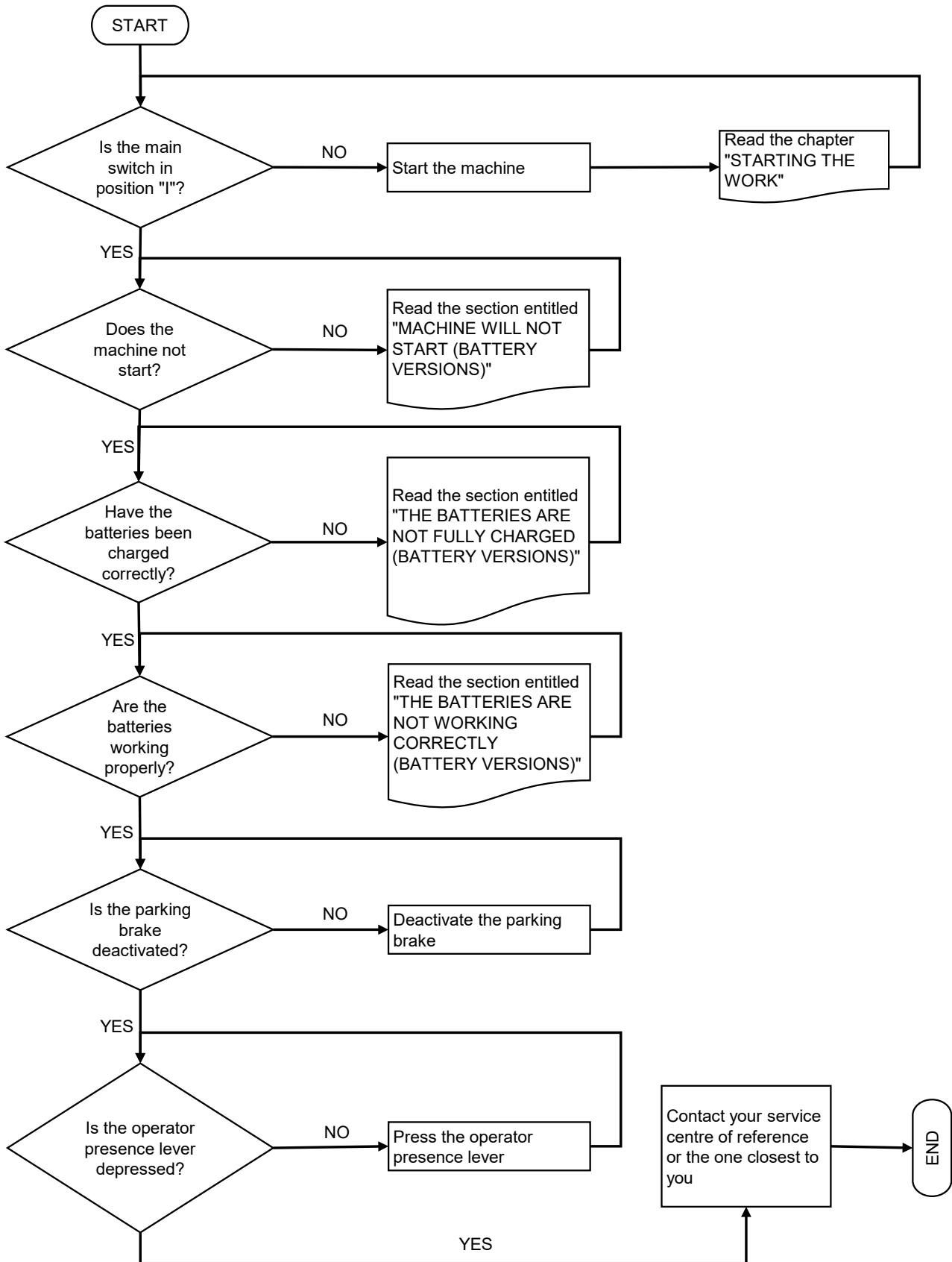

THE MACHINE DOES NOT CLEAN CORRECTLY

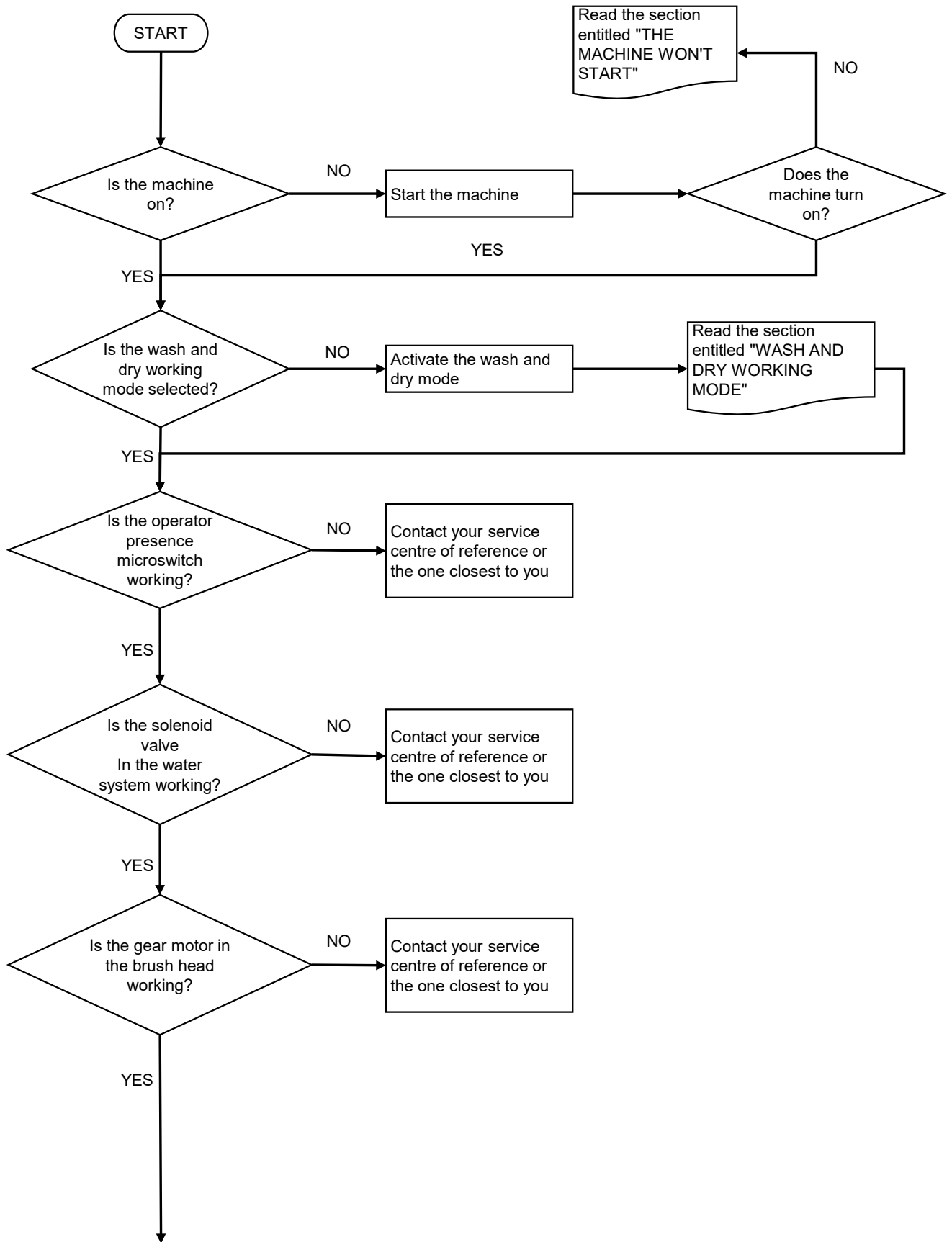

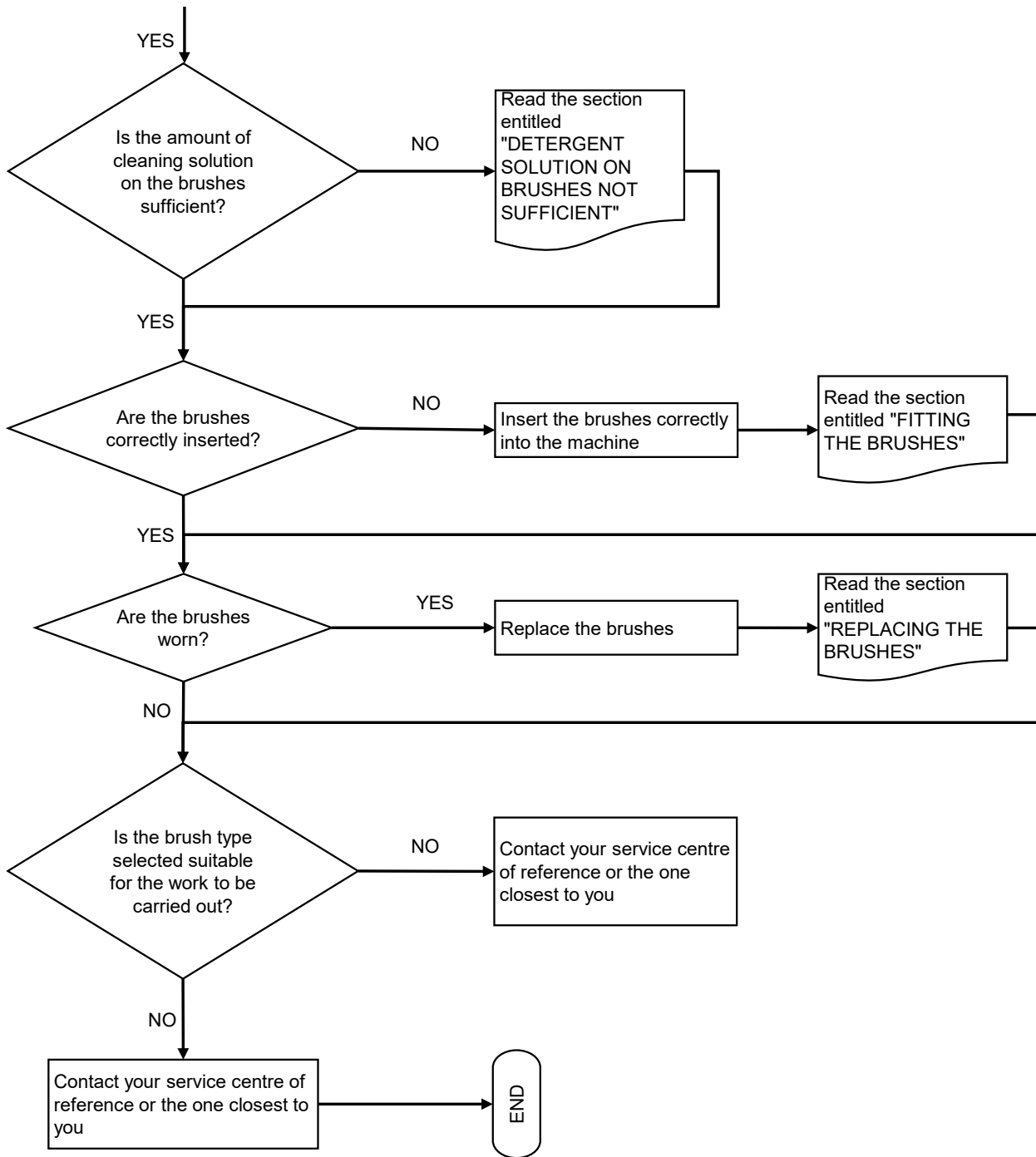

INSUFFICIENT DETERGENT SOLUTION ON THE BRUSHES

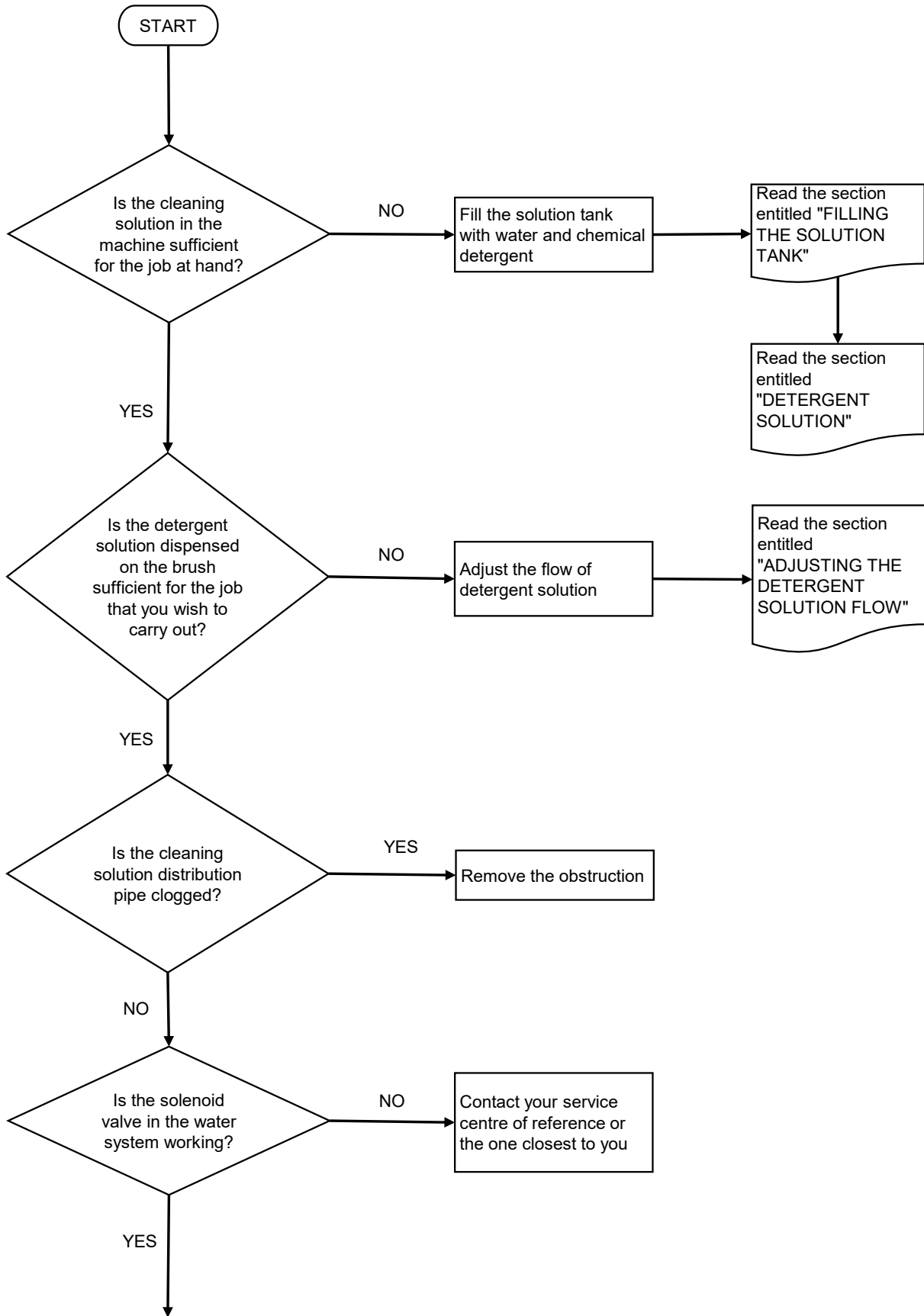

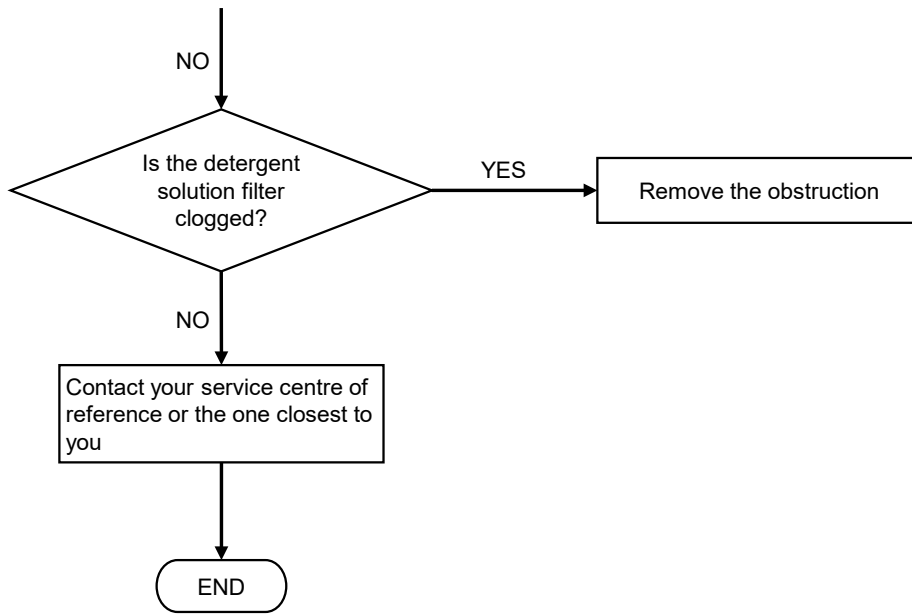

THE VACUUM SYSTEM DOES NOT WORK PROPERLY

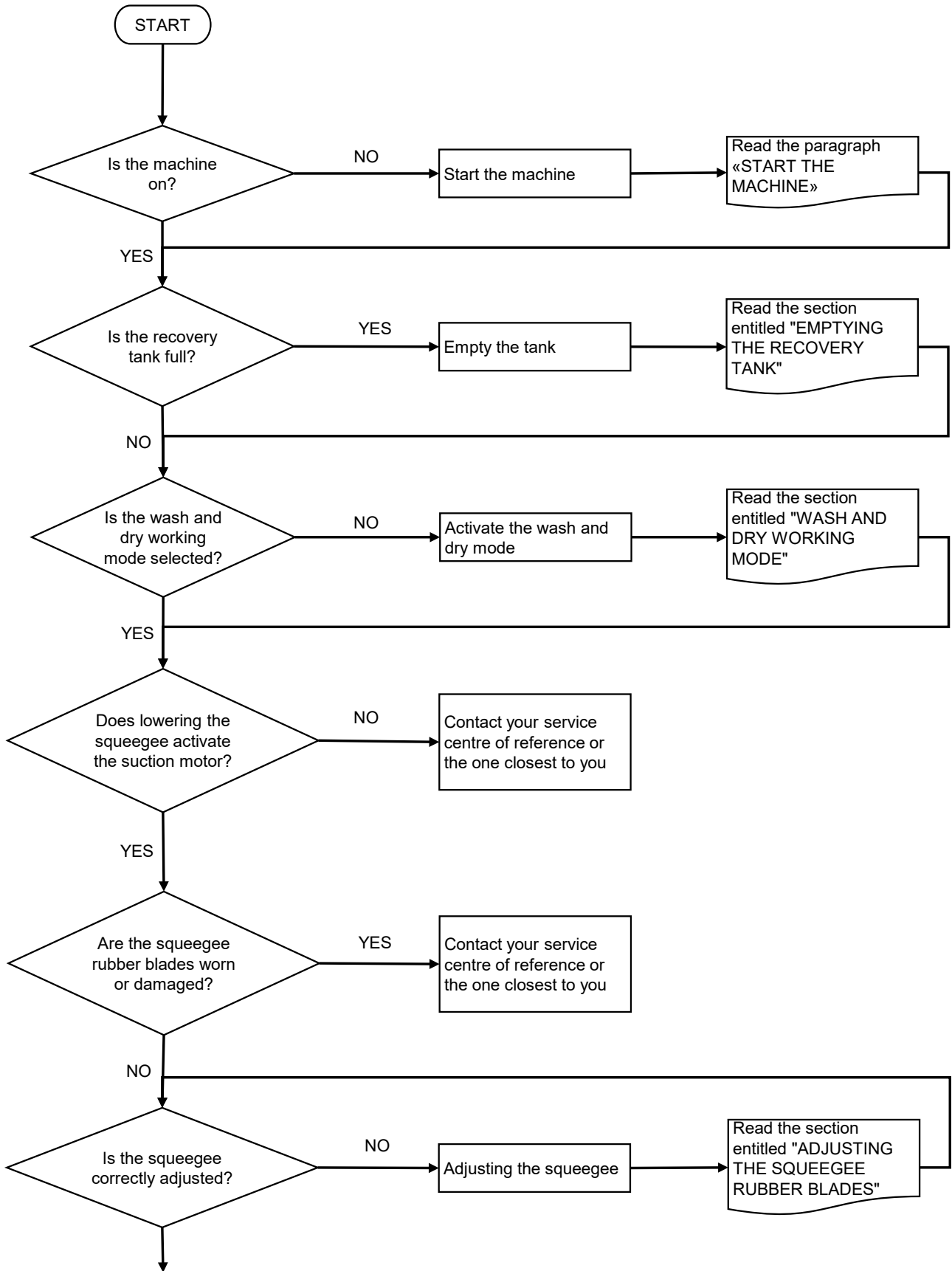

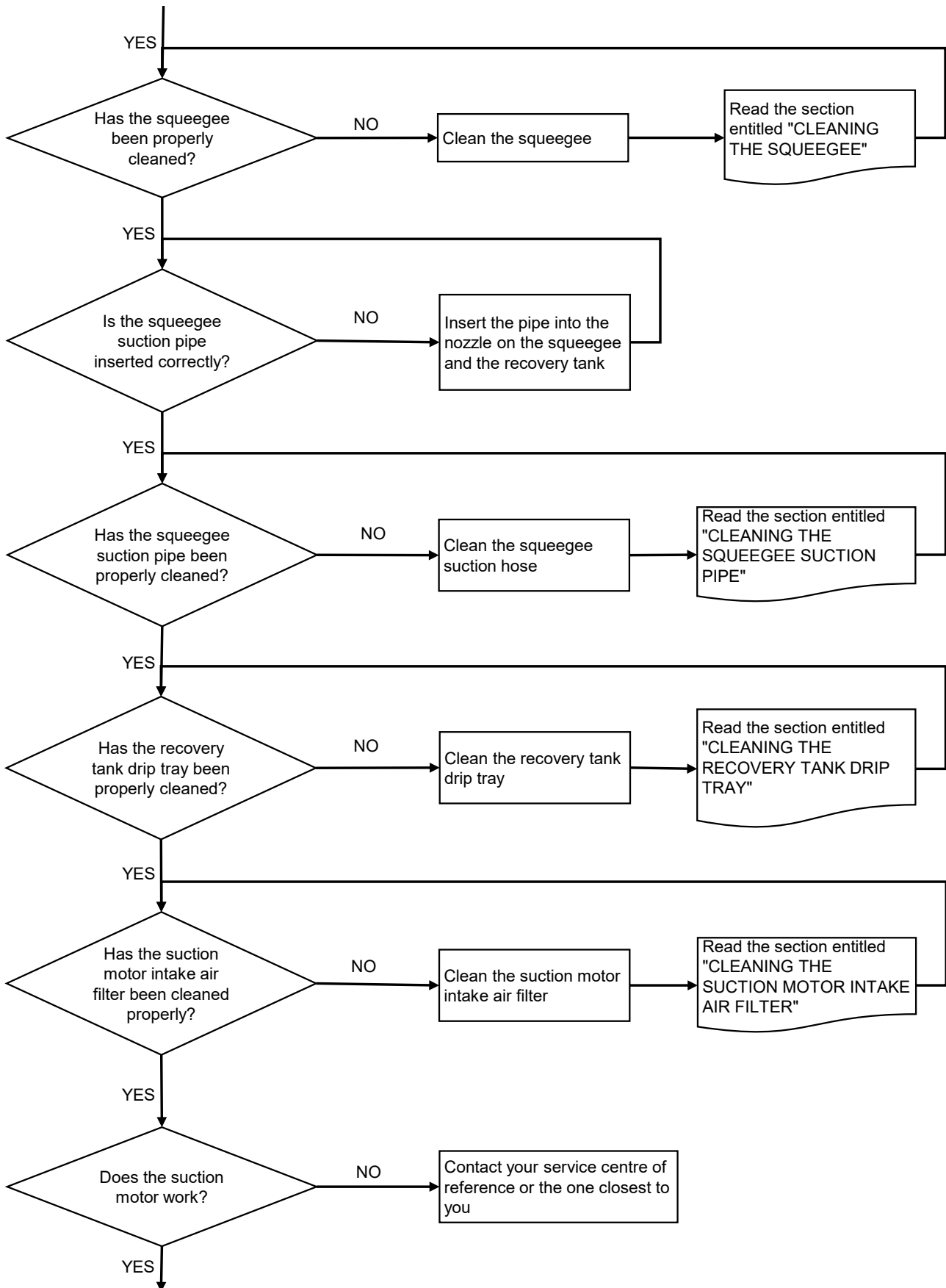

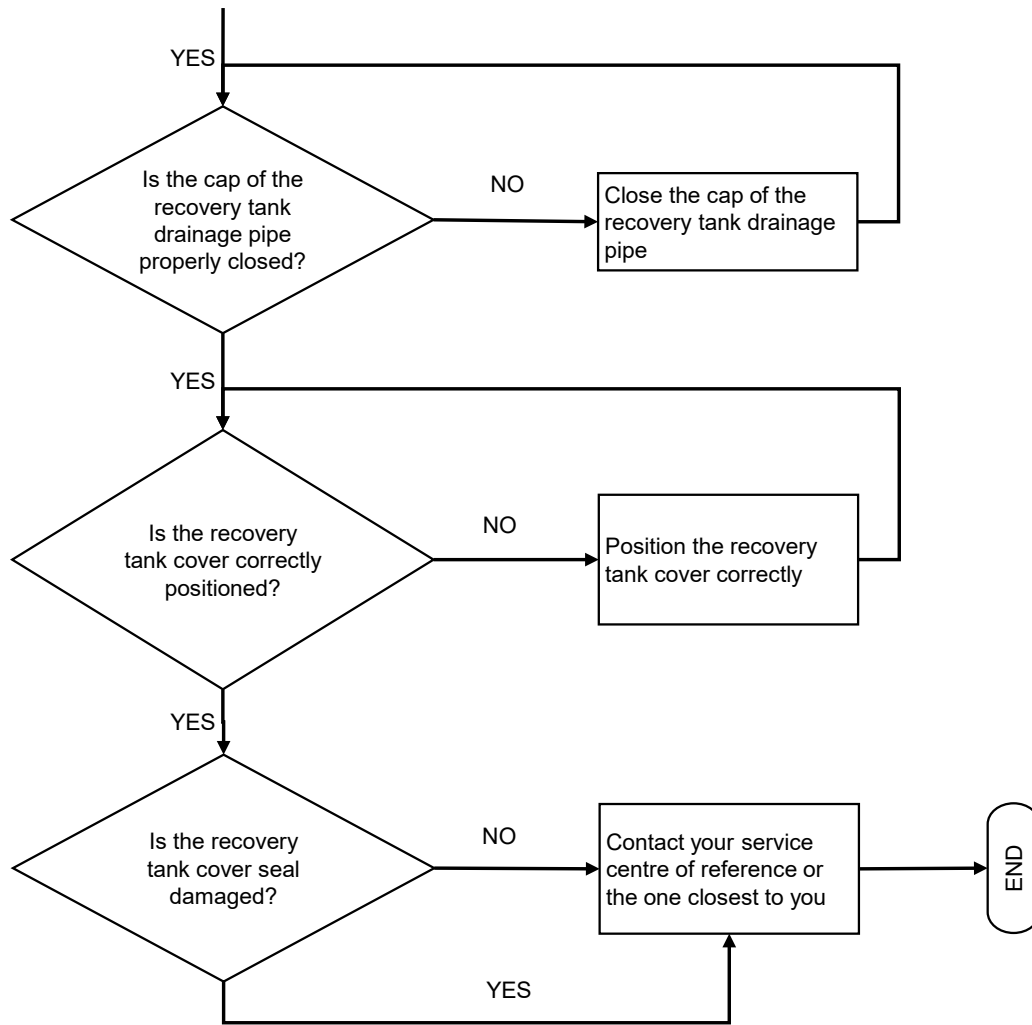

EXCESSIVE FOAM PRODUCTION

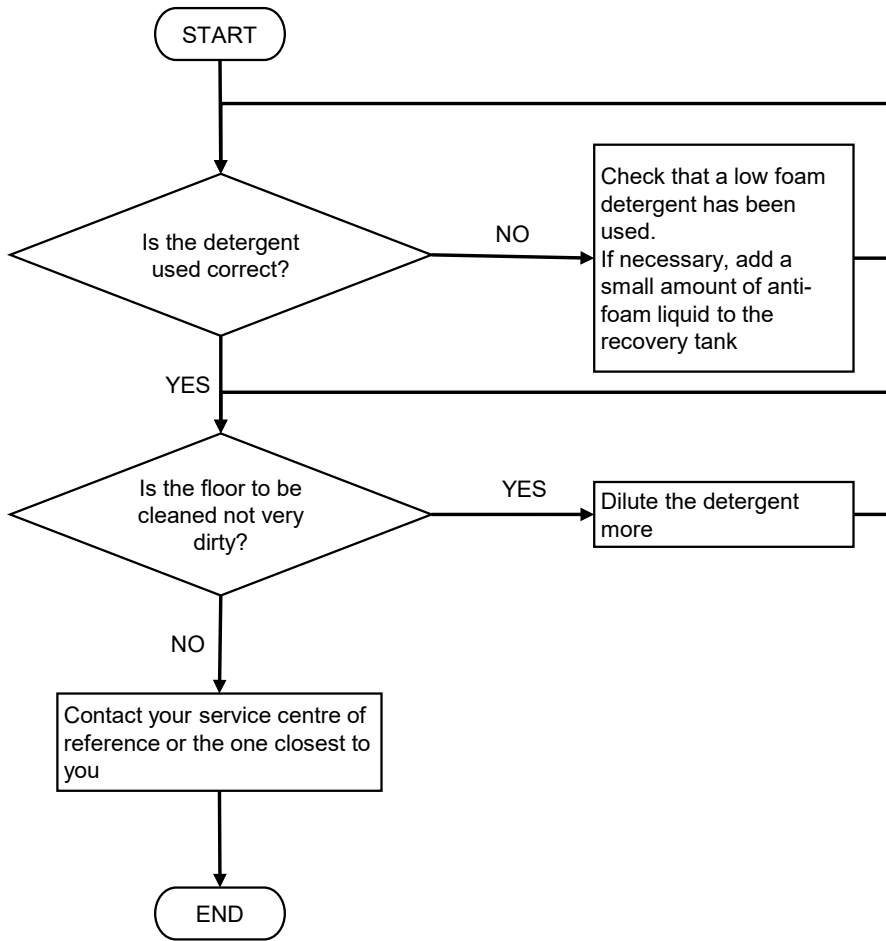

EC DECLARATION OF CONFORMITY



The undersigned manufacturer:

FIMAP S.p.A.
Via Invalidi del Lavoro, 1
37059 Santa Maria di Zevio (VR)

declares under its sole responsibility that the products

FLOOR SCRUBBING MACHINES

mod. JMX 43 B BASIC; JMX 43 B; JMX 50 B BASIC; JMX 50 B

comply with the requirements of the following Directives:

- 2006/42/EC: Machinery Directive.
- 2014/30/EU: Electromagnetic compatibility directive.

The person authorized to compile the technical file:

Mr. Giancarlo Ruffo
Via Invalidi del Lavoro, 1
37059 Santa Maria di Zevio (VR) - ITALY

Santa Maria di Zevio (VR), 03/02/2025
FIMAP S.p.A.
Legal representative
Giancarlo Ruffo



The undersigned manufacturer:

FIMAP S.p.A.
Via Invalidi del Lavoro, 1
37059 Santa Maria di Zevio (VR)

declares under its sole responsibility that the products

FLOOR SCRUBBING MACHINES

mod. JMX 43 B BASIC CB; JMX 43 B CB; JMX 50 B BASIC CB; JMX 50 B CB

comply with the requirements of the following Directives:

- 2006/42/EC: Machinery Directive.
- 2014/35/EU: Low Voltage Directive.
- 2014/30/EU: Electromagnetic compatibility directive.

The person authorized to compile the technical file:

Mr. Giancarlo Ruffo
Via Invalidi del Lavoro, 1
37059 Santa Maria di Zevio (VR) - ITALY

Santa Maria di Zevio (VR), 03/02/2025
FIMAP S.p.A.
Legal representative
Giancarlo Ruffo

A handwritten signature in black ink, appearing to read "G. Ruffo", positioned below the printed name of the legal representative.

UKCA DECLARATION OF CONFORMITY

The undersigned manufacturer:

FIMAP S.p.A.
Via Invalidi del Lavoro, 1
37059 Santa Maria di Zevio (VR)

declares under its sole responsibility that the products

FLOOR SCRUBBING MACHINES

mod. JMX 43 B BASIC; JMX 43 B; JMX 50 B BASIC; JMX 50 B

comply with the requirements of the following Directives:

- S.I. 2008/1597 Supply of Machinery (Safety) Regulations 2008 (as amended).
- S.I. 2016:1091 Electromagnetic Compatibility Regulations 2016 (as amended).

The person authorized to compile the technical file:

Mr. Giancarlo Ruffo
Via Invalidi del Lavoro, 1
37059 Santa Maria di Zevio (VR) - ITALY

Santa Maria di Zevio (VR), 03/02/2025
FIMAP S.p.A.
Legal representative
Giancarlo Ruffo



The undersigned manufacturer:

FIMAP S.p.A.
Via Invalidi del Lavoro, 1
37059 Santa Maria di Zevio (VR)

declares under its sole responsibility that the products

FLOOR SCRUBBING MACHINES

mod. JMX 43 B BASIC CB; JMX 43 B CB; JMX 50 B BASIC CB; JMX 50 B CB

comply with the requirements of the following Directives:

- S.I. 2008/1597 Supply of Machinery (Safety) Regulations 2008 (as amended).
- S.I. 2016:1101 Electrical Equipment (Safety) Regulations 2016 (as amended).
- S.I. 2016:1091 Electromagnetic Compatibility Regulations 2016 (as amended).

The person authorized to compile the technical file:

Mr. Giancarlo Ruffo
Via Invalidi del Lavoro, 1
37059 Santa Maria di Zevio (VR) - ITALY

Santa Maria di Zevio (VR), 03/02/2025
FIMAP S.p.A.
Legal representative
Giancarlo Ruffo

A handwritten signature in black ink, appearing to read "G. Ruffo", positioned below the printed name of the legal representative.



FIMAP S.p.A.

✉ Via Invalidi del Lavoro, 1
37059 S. Maria di Zevio (VR)
Italy

☎ +39 045 6060491 - 📠 +39 045 6060440

@ service@fimap.com 🌐 www.fimap.com